

# DUAL BROADBAND PLC TRANSFORMER

## DT1142CE

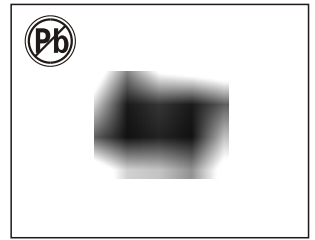

### FEATURES:

- DESIGN FOR PLC(POWER LINE COMMUNICATION) APPLICATION.
- ROHS COMPLIANT.
- REINFORCED INSULATION
- OPERATING TEMPERATURE RANGE: -40°C TO 125°C.

Electrical Specifications @25°C									
Part Number	Turns Ratio @100KHz,1V	OCL @100KHz 0.1V			IL @2MHz-200MHz	DCR @25°C			HI-POT (Pri To Sec)
		1-2,3-4 5-6,7-8	16-15 12-11	14-13 10-9		1-2,3-4 5-6,7-8	16-15 12-11	14-13 10-9	
DT1142CE	1.5:1.5:1:3±5%	17uH Min	7.5uH Min	70uH Min	2.0dB Max	160mΩ Max	60mΩ Max	240mΩ Max	1000Vrms, 1mA,2S

### MECHANICAL DIMENSIONS(unit:mm)

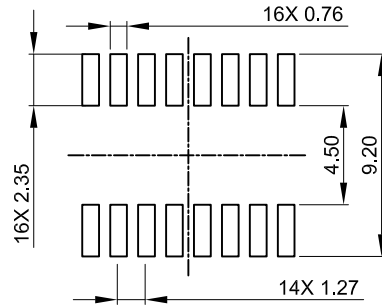
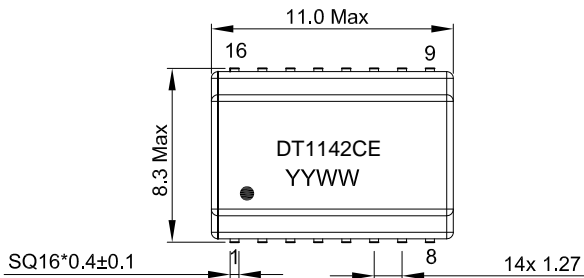

SUGGESTED PAD LAYOUT

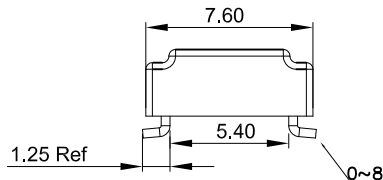
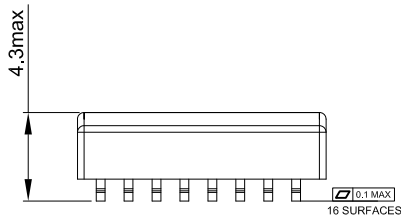

● Unless otherwise specified all tolerances are:±0.25mm

### SCHEMATICS

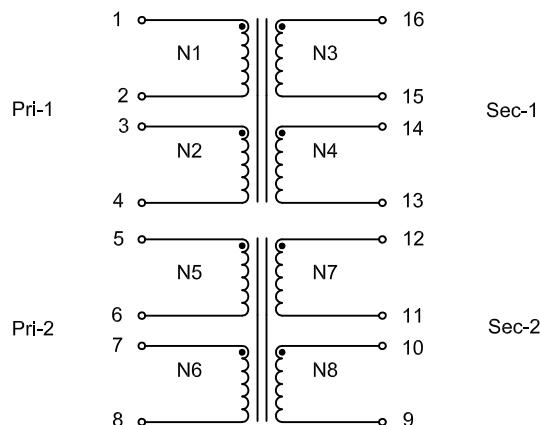

N1:N2:N3:N4=1.5:1.5:1:3  
N5:N6:N7:N8=1.5:1.5:1:3

# BROADBAND PLC TRANSFORMER

## T002DG



### FEATURES:

- POWER LINE COMMUNICATION TRANSFORMER
- OPERATING TEMPERATURE RANGE: 0°C TO70°C
- STORAGE TEMPERATURE RANGE: -40°C TO +85°C
- ROHS COMPLIANT

Electrical Specifications @25°C									
Part Number	Turns Ratio		OCL (@100KHz,0.1V)			Insertion Loss		Frequency Range	Hi-pot
	P1-6:P5-2	P1-6:P4-3	P1-6	P5-2	P4-3	P1-6:P5-2	P1-6:P4-3	MHz	
T002DG	3:4±5%	3:1±5%	18.3uH±45%	32.5uH±45%	2.0uH±45%	2.0dB Max	6.0dB Max	2-70	3000VAC/60S

### MECHANICAL

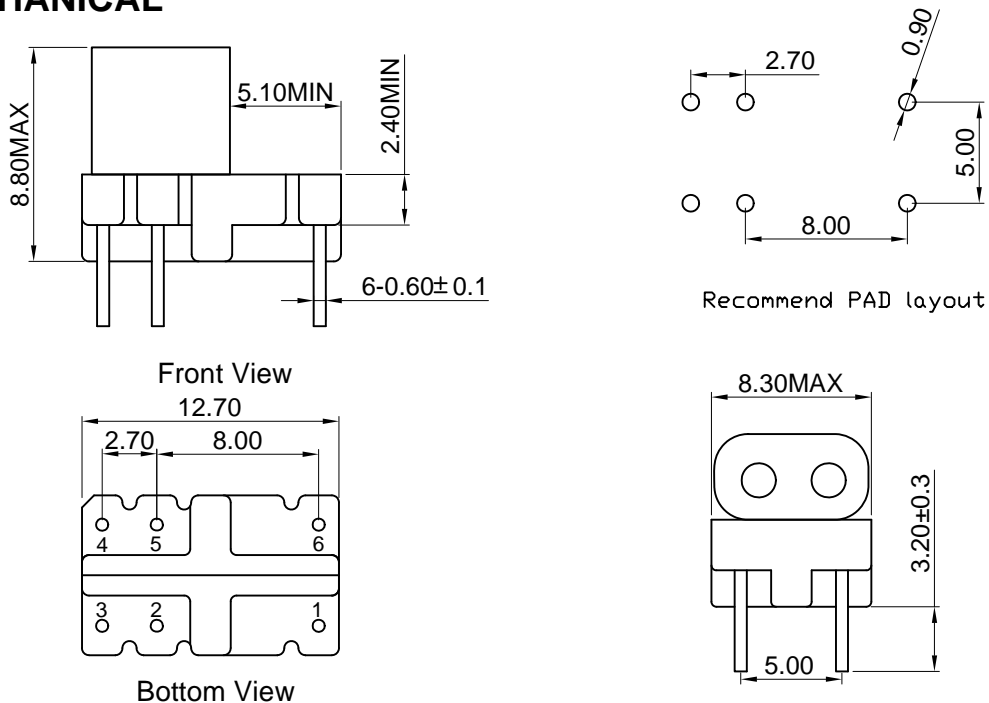

Unless otherwise specified all tolerances are:±0.25 mm

### SCHEMATICS

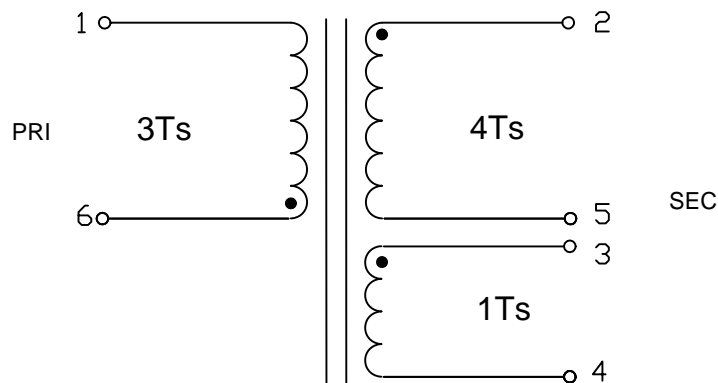

# BROADBAND PLC TRANSFORMER

## T006DG



### FEATURES:

- POWER LINE COMMUNICATION TRANSFORMER
- OPERATING TEMPERATURE RANGE: 0°C TO 70°C
- STORAGE TEMPERATURE RANGE: -40°C TO +85°C
- ROHS COMPLIANT

Electrical Specifications @25°C					
Part Number	Turns Ratio	OCL (@2MHz,0.1V)	Insertion Loss	Frequency Range	Hi-pot
	T006DG	Pri:Sec/1-3:4-6 1:1±5%	1-3=4-6 12.5-30.0uH	2-68 MHz 3.0dB Max	MHz 2-68

### MECHANICAL

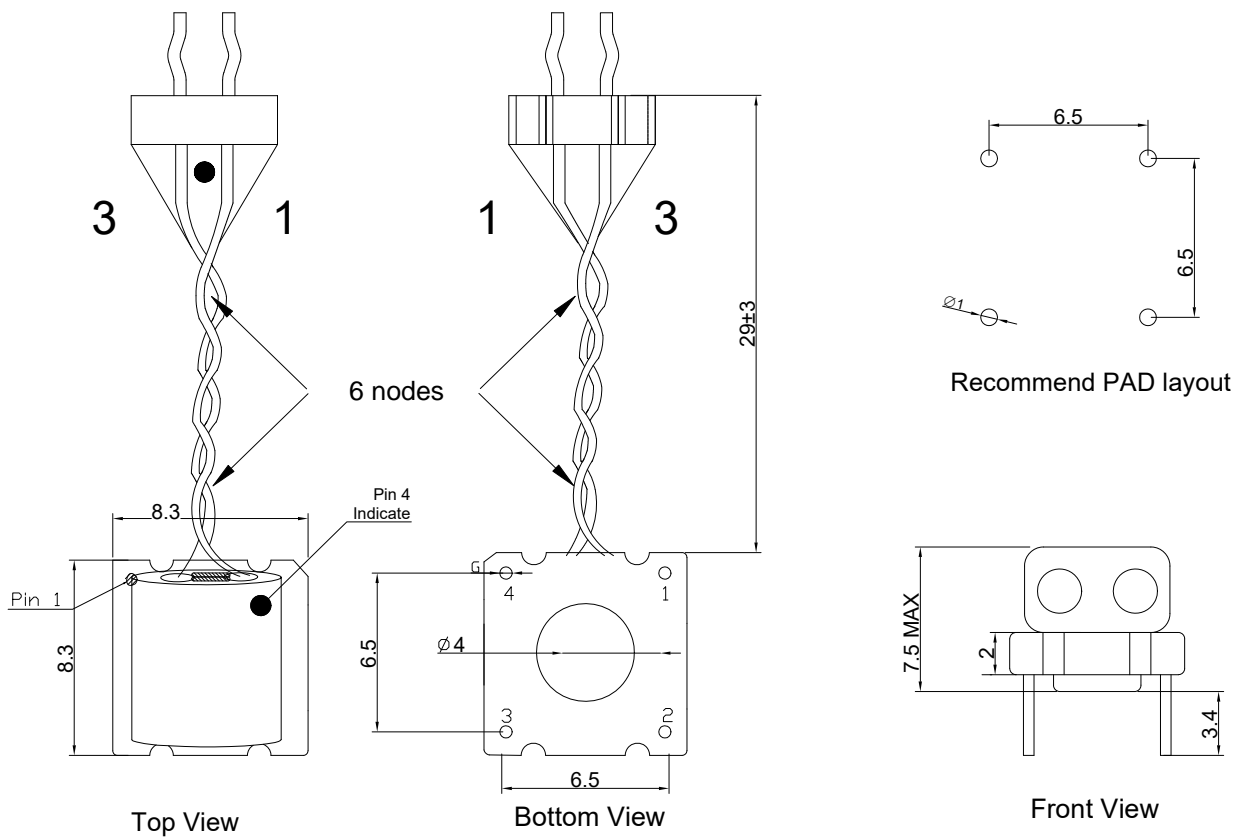

### SCHEMATICS

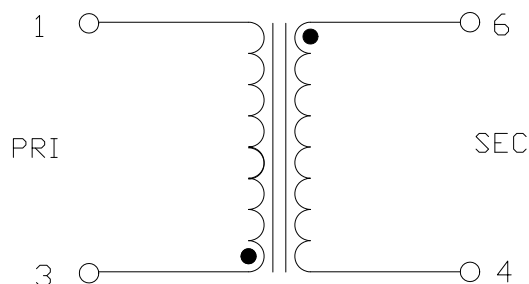

# BROADBAND PLC TRANSFORMER

## T008DG

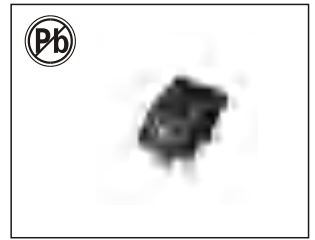

### FEATURES:

- POWER LINE COMMUNICATION TRANSFORMER
- OPERATING TEMPERATURE RANGE: 0°C TO70°C
- STORAGE TEMPERATURE RANGE: -40°C TO +85°C
- ROHS COMPLIANT

Electrical Specifications @25°C								
Part Number	Turns Ratio		OCL (@10KHz,1V)	LK (@1MHz,0.1V)	DCR			Hi-pot
	P1-6:P3-4	P1-6:2-5	P1-6	P1-6 (short other)	P1-6	P2-5	P3-4	3750VAC 0.5mA/1S
T008DG	1:1±5%	3:1±5%	9.5uH Min	225nH Max	350 mΩ Max	150 mΩ Max	300 mΩ Max	

### MECHANICAL

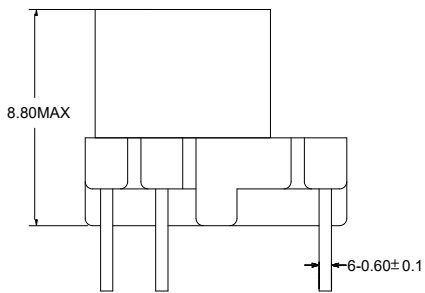

Front View

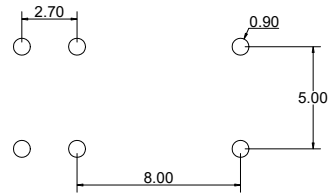

Recommend PAD layout

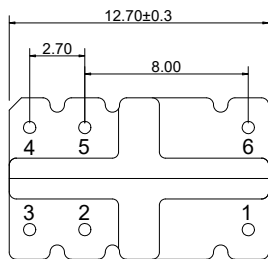

Bottom View

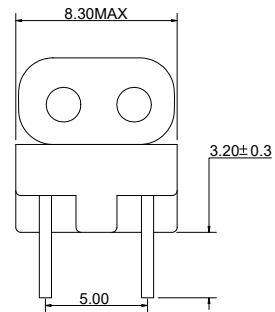

Unless otherwise specified all tolerances are:±0.25 in mm

### SCHEMATICS

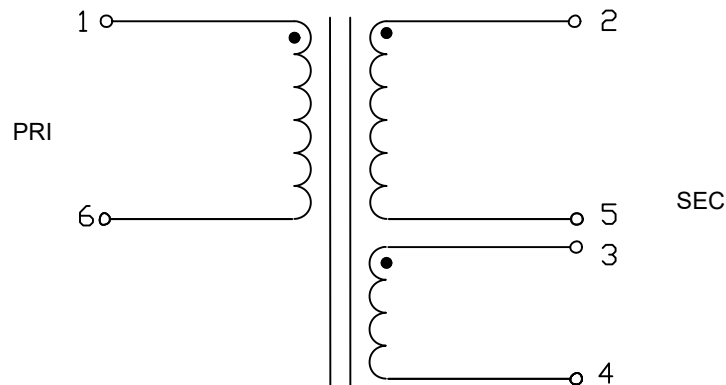

# BROADBAND PLC TRANSFORMER

## T012DG

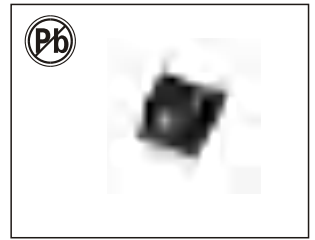

### FEATURES:

- POWER LINE COMMUNICATION TRANSFORMER
- OPERATING TEMPERATURE RANGE: 0°C TO70°C
- STORAGE TEMPERATURE RANGE: -40°C TO +85°C
- ROHS COMPLIANT

Electrical Specifications @25°C					
Part Number	Turns Ratio	OCL (@2MHz,0.1V)	Insertion Loss	Frequency Range	Hi-pot
		Pri:Sec/1-4:5-8	1-4=5-8	2-68 MHz	MHz
T012DG	1:1±5%	21.5uH±45%	3.0dB Max	2-68	

### MECHANICAL

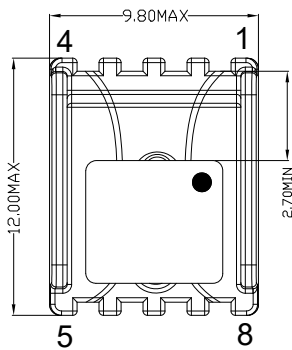

TOP VIEW

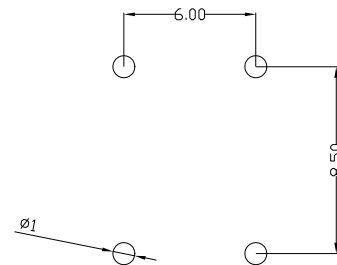

Recommend PAD layout

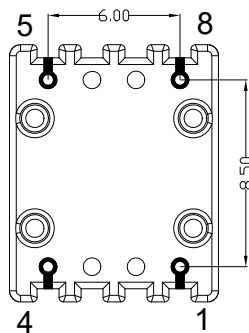

BOTTOM VIEW

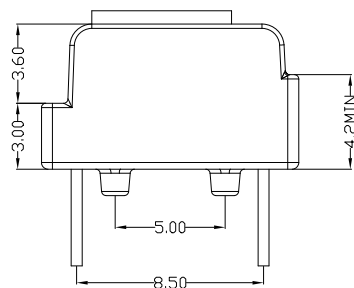

SIDE VIEW

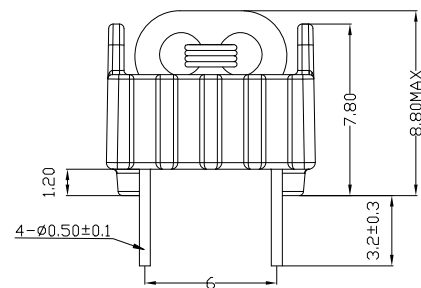

FRONT VIEW

Unless otherwise specified all tolerances are:±0.25 in mm

### SCHEMATICS

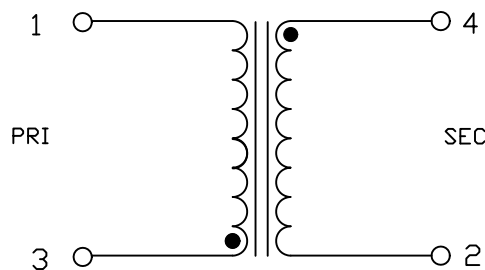

# BROADBAND PLC TRANSFORMER

## T038DG



### FEATURES:

- POWER LINE COMMUNICATION TRANSFORMER
- OPERATING TEMPERATURE RANGE: 0°C TO 70°C
- STORAGE TEMPERATURE RANGE: -40°C TO +85°C
- ROHS COMPLIANT

Electrical Specifications @25°C							
Part Number	Turns Ratio (@100KHz,0.1V)		OCL (@100KHz,0.1V)			Frequency Range	Hi-pot
	P(S-F):P(1-4)	P(S-F):P(3-2)	P(S-F)	P(1-4)	P(3-2)	MHz	3000VAC/3S
T038DG	3:4±5%	3:1±5%	9.5uH Min	16.9uH Min	1.05uH Min	2-30	

### MECHANICAL

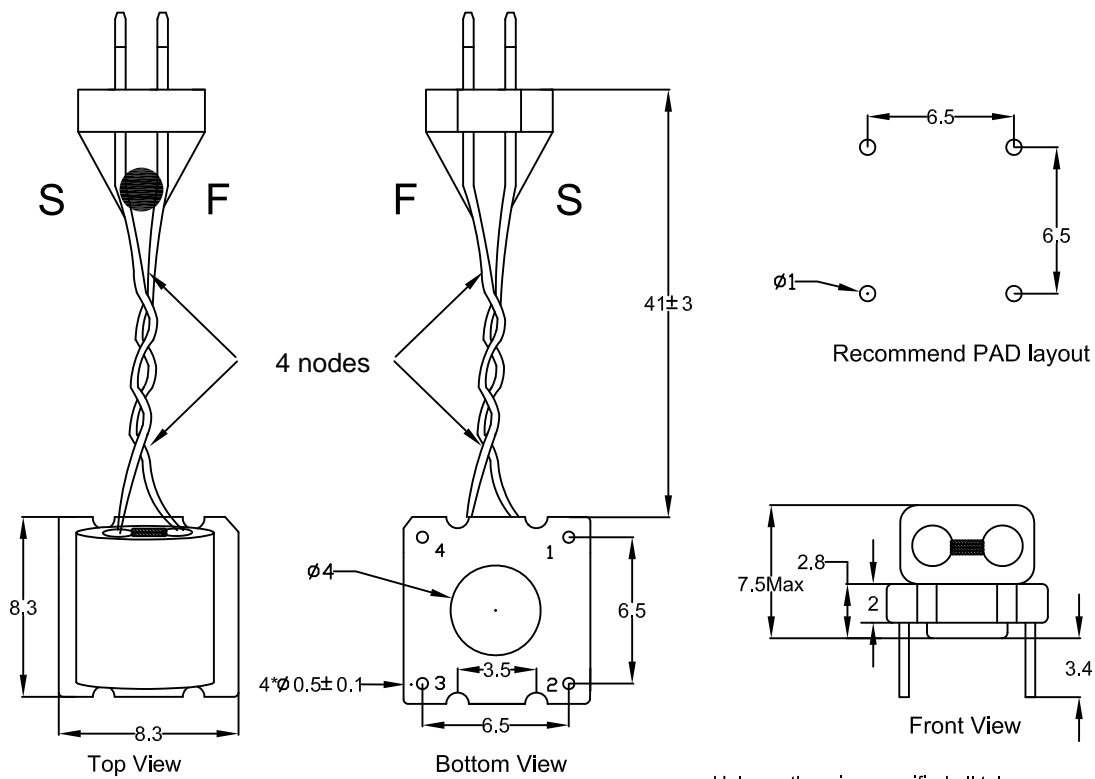

Unless otherwise specified all tolerances are:  $\pm 0.25$  in mm

### SCHEMATICS

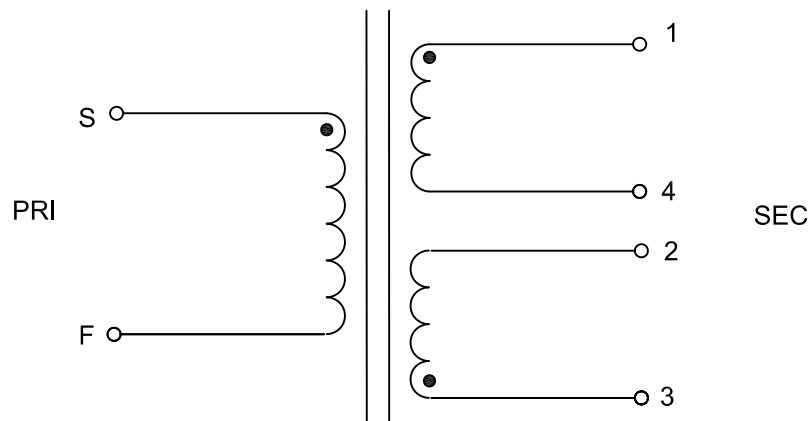

# BROADBAND PLC TRANSFORMER

## T047DG

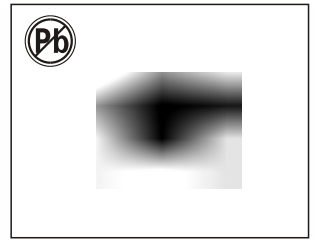

### FEATURES:

- DESIGN FOR PLC(POWER LINE COMMUNICATION) APPLICATION.
- ROHS COMPLIANT.
- REINFORCED INSULATION
- OPERATING TEMPERATURE RANGE: 0°C TO 70°C.

Electrical Specifications @25°C							
Part Number	Turns Ratio (@100KHz,0.1V)	OCL (@100KHz,0.1V)			DCR(@25°C)		
	6-1:2-5:3-4	6-1	2-5	3-4	6-1	2-5	3-4
	(3.5:4:2)±5%	34.3uH Min	44.8uH Min	11.2uH Min	0.5Ω max	0.5Ω max	0.25Ω max
T047DG	<b>Continue</b>						
	Hi-pot	Insulation resistance 500VDC/1mA		INSERTION LOSS 1-6 To 2-5 (Measure back to back)		INSERTION LOSS 6-1 To 3-4 (Measure back to back)	
	6-1To 2-5,3-4	6-1To 2-5,3-4		2-68MHz		2-68MHz	
	500VDC/1mA/2S	5MΩ Min		-3.0dB Min		-6.0dB Min	

## MECHANICAL DIMENSIONS(unit:mm)

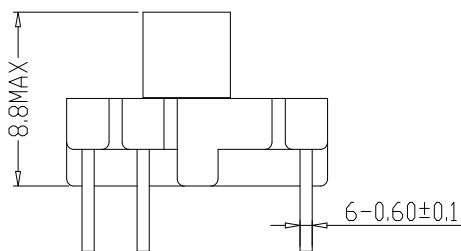

Front View

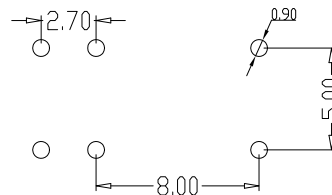

Recommend PAD layout

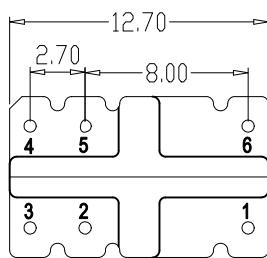

Bottom View

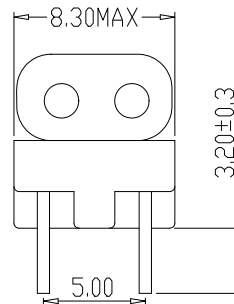

● Unless otherwise specified all tolerances are:±0.25mm

## SCHEMATIC

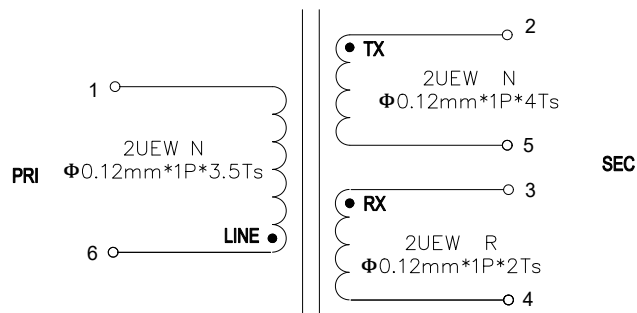

# BROADBAND PLC TRANSFORMER

## T049DG

### FEATURES:

- DESIGN FOR PLC(POWER LINE COMMUNICATION) APPLICATION.
- ROHS COMPLIANT.
- REINFORCED INSULATION
- OPERATING TEMPERATURE RANGE: -40°C TO 85°C.

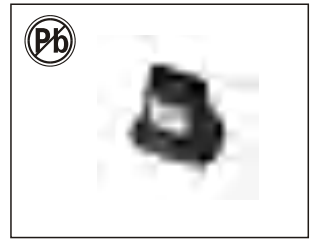

Electrical Specifications @25°C						
Part Number	Turns Ratio 100KHz,1.0V	OCL 1.0KHz,1.0V		DC Resistance		Hi-pot 3-4 To1-6, 2-5
		P1-6:P2-5:P3-4	P2-5=P3-4	P1-6	P2-5=3-4	P1-6
T049DG	1:2:2±5%	28.0uH MIN	7.0uH MIN	34mΩ MAX	22mΩ MAX	

### MECHANICAL DIMENSIONS(unit:mm)

heat shrink tubing

The core must not exceed this side

The core shifts to Pin1-3

Front View

DIM	MILLIMETERS (Units:mm)
A	12.7±0.3
B	12.0 Max
C	12.5 Max
D	3.2±0.3
E1	2.7±0.3
E2	8.0±0.3
F1	5.0±0.5
G1	0.6±0.1
E3	2.7 Typ
E4	8.0 Typ
F2	5.0 Typ
G2	1.0 Typ

Bottom View

SUGGESTED PAD LAYOUT

● Unless otherwise specified all tolerances are:±0.25mm

### SCHEMATIC

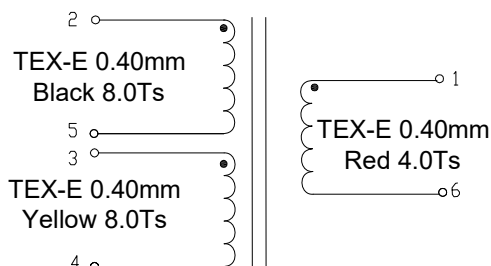

# BROADBAND PLC TRANSFORMER

## T096SG

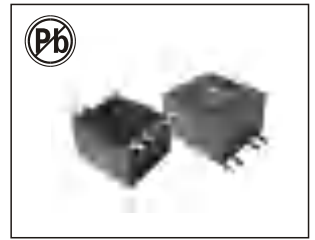

### FEATURES:

- DESIGN FOR PLC(POWER LINE COMMUNICATION) APPLICATION .
- ROHS COMPLIANT.
- SUPPLEMENTARY INSULATION.
- OPERATING TEMPERATURE RANGE: -40 °C TO +85 °C.

Electrical Specifications @25°C							
Part Number	OCL (@100KHz,1V)		Lk(@100KHz,1V)	DCR			Hi-pot
	8-5(Shorted6-7)	3-4	3-4	5-8(Shorted6-7)	3-4	1-2	PRI TO SEC 3750VAC/1S
T096SG	1.4uH Min	2.5uH Min	300nH Max	0.095ohm MAX	0.075ohm MAX	0.045ohm MAX	

### MECHANICAL DIMENSIONS(unit:mm)

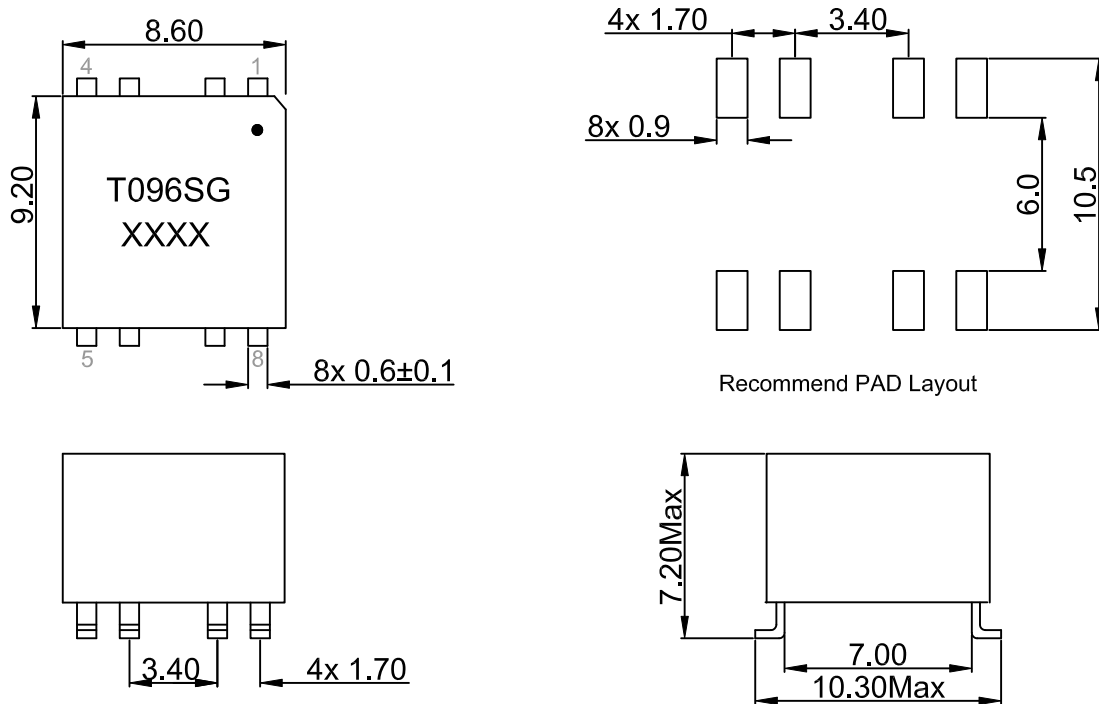

• Unless otherwise specified all tolerances are:±0.25mm

### SCHEMATIC

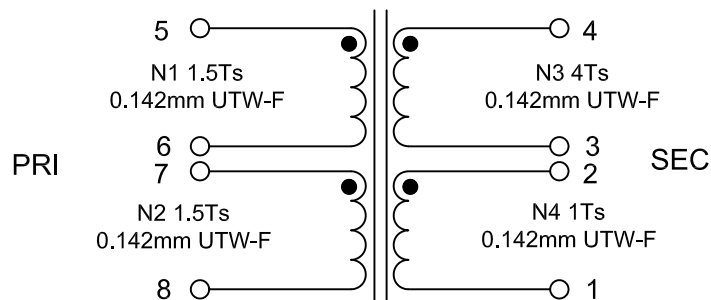

Rev.	Description	Date
A0	New release	2023.05.10

### 1. PHYSICAL CHARACTERISTICS (mm)

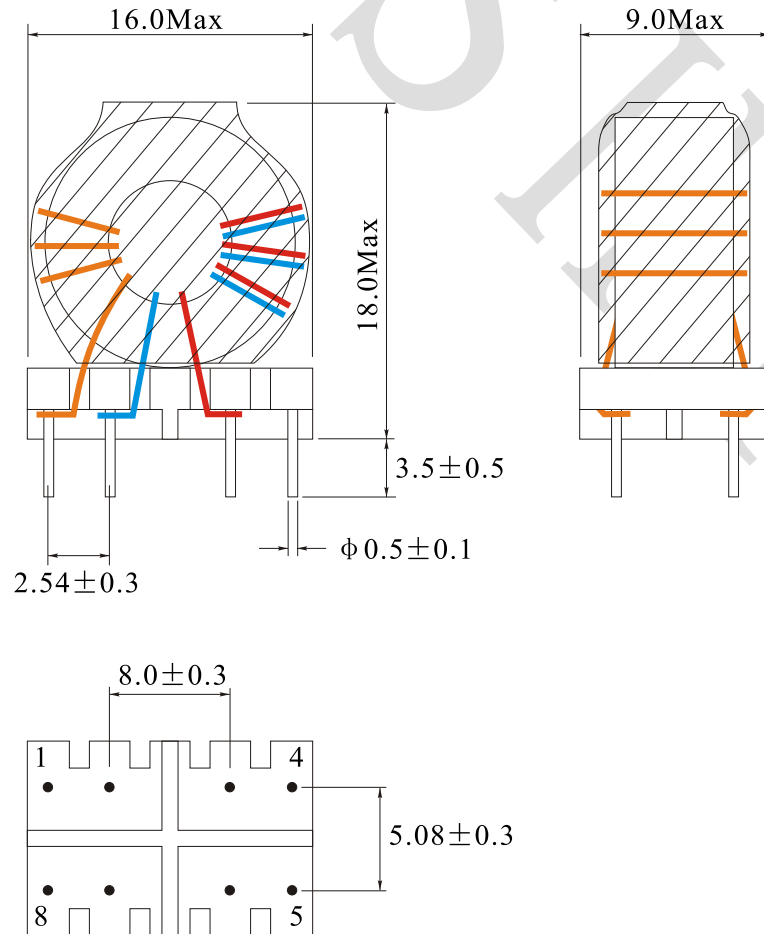

### 2. ELECTRONICAL SCHEMATIC

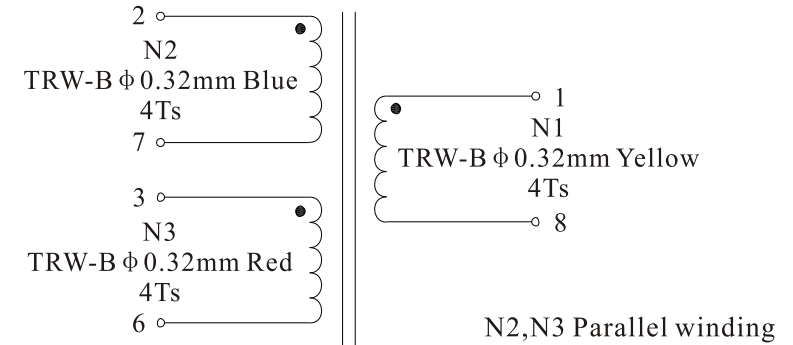

### 3. ELECTRONICAL SPECIFICATIONS

Turns ratio: (1-8):(2-7):(3-6)=1:1:1

Inductance(each winding): 7.0uH±30%@1.0KHz,1V

DCR(each winding): 30mΩ Max

Hi-Pot: 3000Vac,5mA,60S Coil to Core

3000Vac,5mA,60S Pin1,2,7,8 to Pin 3,6

Operating temperature: -40°C to +105°C

Storage temperature: -20°C to +65°C

NAME:	Isolation transformers for broadband PLC system		
CUSTOMER P/N:		DATE:	2023-05-10
SHINHOM P/N:	T1025	REV:	A0
DRAWN BY:	CHECKED BY:	APPROVE BY:	



**SHINHOM**  
SHAANXISHINHOM ENTERPRISE CO LTD

The Document property belong to SHINHOM & is not allowed to be duplicated without authorization

# BROADBAND PLC TRANSFORMER

## T105SG

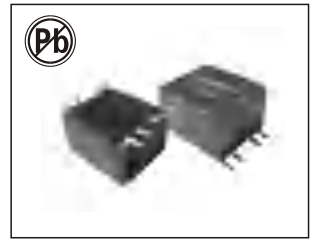

### FEATURES:

- DESIGN FOR PLC(POWER LINE COMMUNICATION) APPLICATION .
- ROHS COMPLIANT.
- SUPPLEMENTARY INSULATION.
- OPERATING TEMPERATURE RANGE: -40 °C TO +85 °C.

### Electrical Specifications @25°C

Part Number	OCL (@100KHz,1V)		LK(@100KHz,1V)	DCR			Hi-pot
	8-5	3-4	3-4	5-8	3-4	1-2	pri to sec 3750VAC/2S
T105SG	1.4uH Min	2.5uH Min	300nH Max	0.095ohm MAX	0.075ohm MAX	0.045ohm MAX	

### MECHANICAL DIMENSIONS(unit:mm)

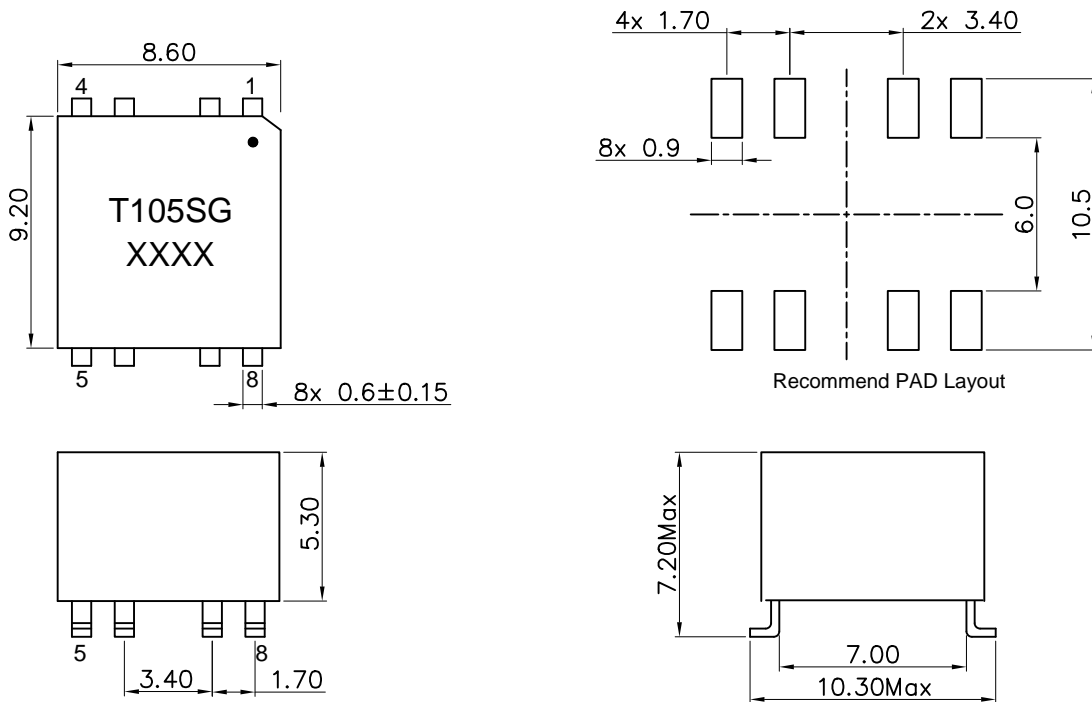

● Unless otherwise specified all tolerances are:±0.25 mm

### SCHEMATICS

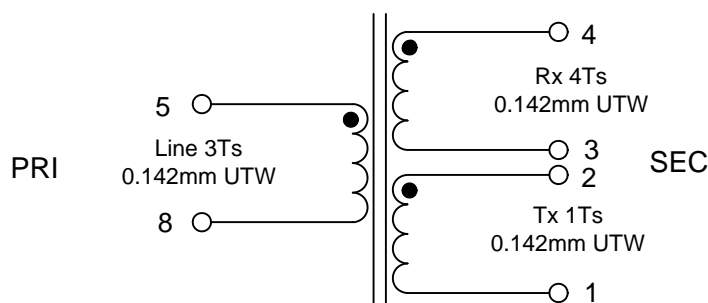

Rev.	Description	Date
A0	New release	2023.05.10

## 1. PHYSICAL CHARACTERISTICS (mm)

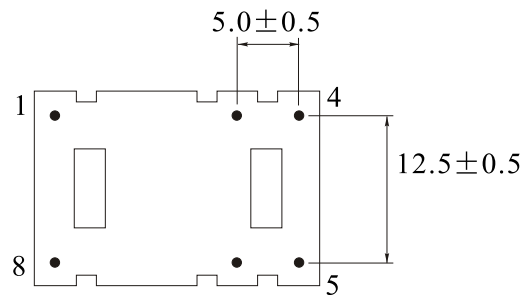
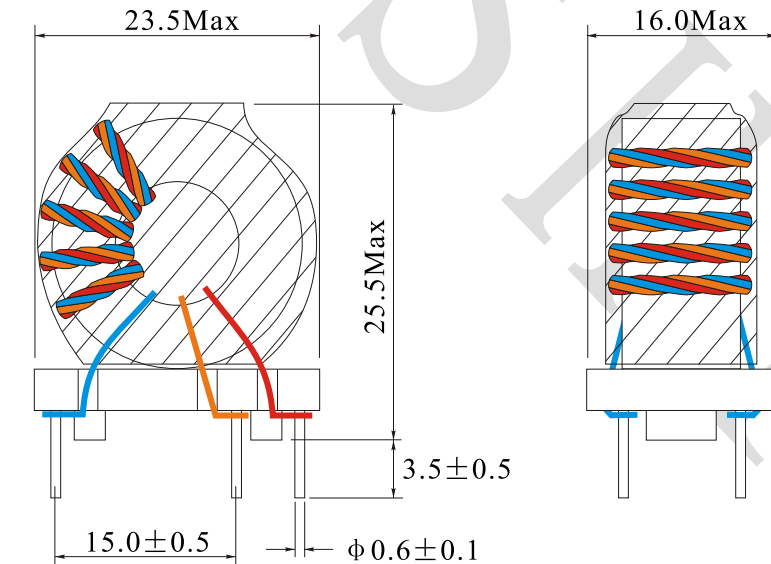

## 2. ELECTRONICAL SCHEMATIC

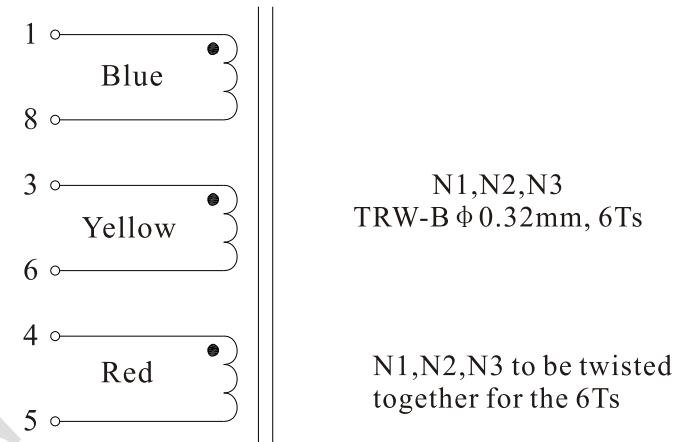

## 3. ELECTRONICAL SPECIFICATIONS

Turns ratio: (1-8):(3-6):(4-5)=1:1:1

Inductance(each winding): 16.5uH±30%@1.0KHz,1V

DCR(each winding): 41mΩ Max

Hi-Pot: 6000Vac,5mA,60S Coil to Core

Operating temperature: -40°C to +105°C

Storage temperature: -20°C to +65°C

NAME:	Isolation transformers for broadband PLC system		
CUSTOMER P/N:		DATE:	2023-05-10
SHINHOM P/N:	T1099	REV:	A0
DRAWN BY	CHECKED BY	APPROVE BY	



**SHINHOM**  
SHAANXISHINHOM ENTERPRISE CO LTD

The Document property belong to SHINHOM & is not allowed to be duplicated without authorization

# BROADBAND PLC TRANSFORMER

## T1110CA

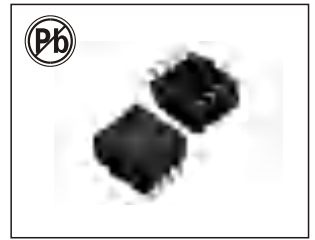

### FEATURES:

- OPERATING TEMPERATURE RANGE: -40 °C TO+125 °C
- SURFACE MOUNT DEVICE PROVIDING COMPACT FOOTPRINT
- ROHS COMPLIANT

ELECTRICAL SPECIFICATIONS @25°C						
Part Number	Turns Ratio @100KHz, 1V	OCL @1MHz 0.1V	OCL@1MHz 0.1V -40°C TO+85°C	L.L @1MHz 0.1V	DCR @25°C	
	1-2:3-4:5-6	1-2,5-6	1-2,5-6	5-6(short1+2+3+4)	1-2,5-6	3-4
T1110CA	1:3:1±5%	16uH Min	10uH Min	0.2uH Max	0.22Ω Max	0.5Ω Max
	CWW@100kHz,1V	Insertion los @0.5-30MHz	Return loss @0.5-30MHz	IR	HI-POT (PLTo TX, TX)	
	1-6(short2+3)	5-6 To 1-2	5-6 To 1-2	500VDC	3000Vrms, 1mA,60S	
	15pF Max	-1.0dB MAX	-10.0dB Min	100MΩ MIN		

### MECHANICAL DIMENSIONS

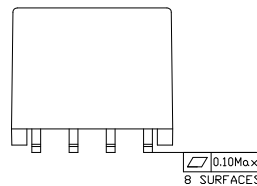
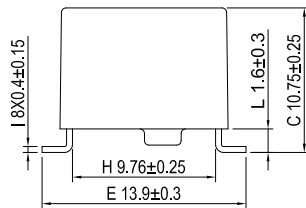
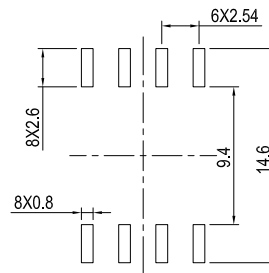
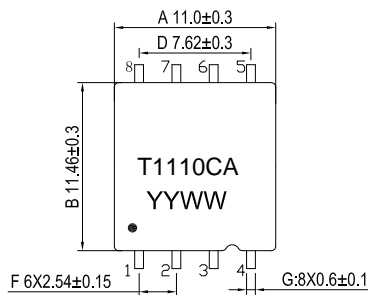

• Unless otherwise specified all tolerances are:±0.25mm

### SCHEMATICS

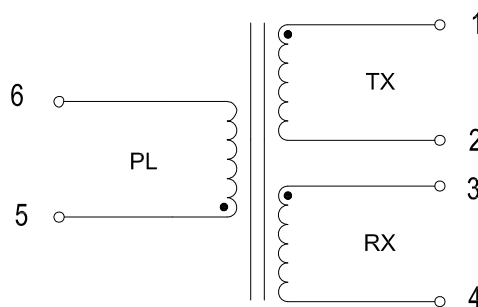

# DUAL BROADBAND PLC TRANSFORMER

## T1113CE

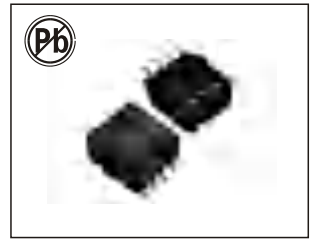

### FEATURES:

- Design For PLC(power line communication) Application.
- RoHS Compliance Product
- Surface Mount Device Providing Compact Footprint
- Operating Temperature Range: -40°C TO +85°C.

Electrical Specifications @25°C							HI-POT (1mA,1S)
Part Number	Turns Ratio @100KHz,1.0V	OCL @100KHz 0.1V 15mA	L.L @100KHz 0.1V	C <sub>ww</sub> @100kHz 0.1V	Insertion loss @2-21MHz dB Max	Return loss @2-21MHz dB Min	
T1113CE	1-2:3-4:5-6 1:1:1±5%	1-2,3-4,5-6 15uH Min	1-4(short2-3,5-6) 0.5uH Max	1-6 10pF Max	3.0	9.0	6000V DC

### MECHANICAL DIMENSIONS(unit:mm)

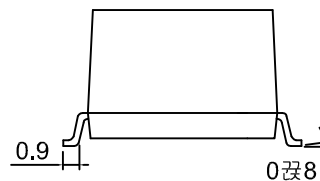
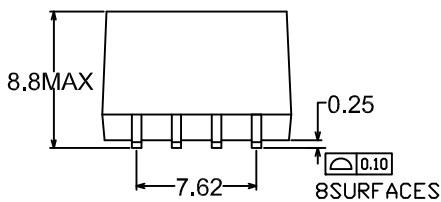
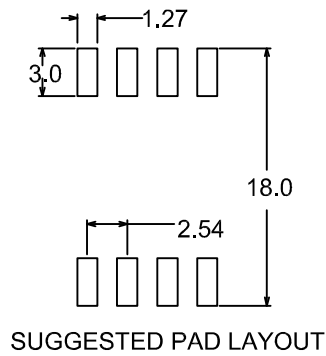
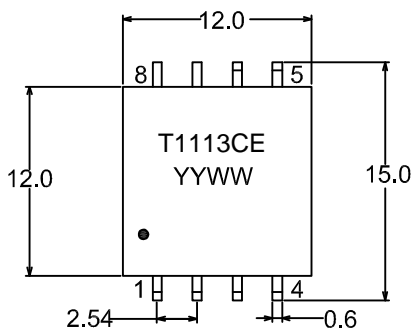

• Unless otherwise specified all tolerances are:±0.25mm

### SCHEMATICS

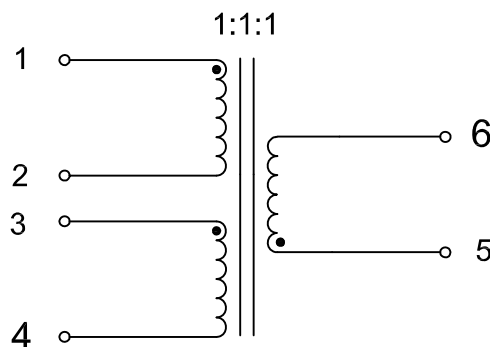

# BROADBAND PLC TRANSFORMER

## T1116CE

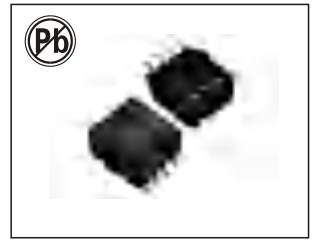

### FEATURES:

- DESIGN FOR PLC(POWER LINE COMMUNICATION) APPLICATION.
- ROHS COMPLIANT.
- REINFORCED INSULATION
- OPERATING TEMPERATURE RANGE: -40°C TO 85°C.

Electrical Specifications @25°C						
Part Number	Turns Ratio @100KHz,0.1V	OCL @100KHz 0.1V	L.L @100KHz 0.1V	Insertion loss	IR (Pri TO Sec)	
T1116CE	1-2:3-4:5-8	1-2,3-4,5-8	5-8(short1+2+3+4)	0.5-20MHz	500VDC 100MΩ Min	
	1:1:1±2%	250uH Min	1.0uH Max	1.0dB MAX		
	Continue					
	DCR @25°C		C <sub>ww</sub> @100KHz 1V	Return loss	HI-POT (Pri TO Sec)	
	1-2,3-4	5-8	1-8	0.5-20MHz	3000Vrms, 0.5mA,60S	
	0.4Ω Max	0.5Ω Max	15pF Max	14dB Min		

### MECHANICAL

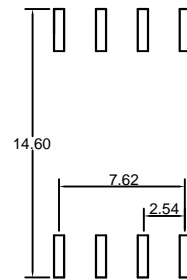
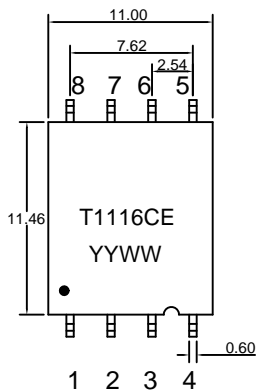

SUGGESTED PAD LAYOUT

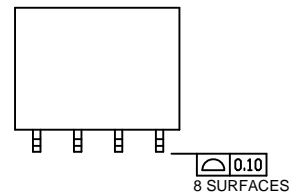
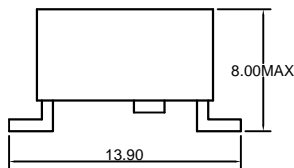

Unless otherwise specified all tolerances are:±0.25 in mm

### SCHEMATICS

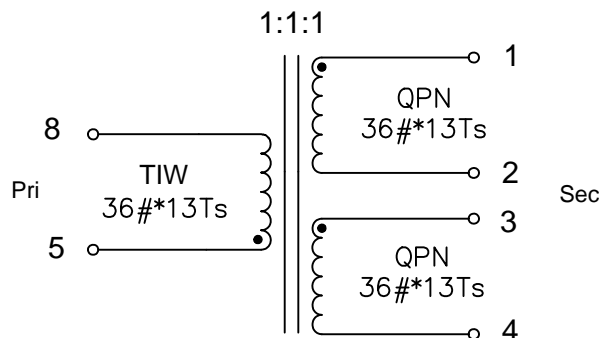

# BROADBAND PLC TRANSFORMER

## T1117CA

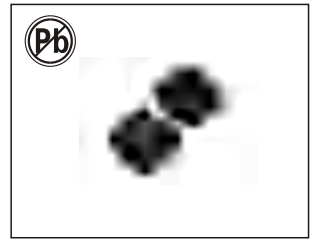

### FEATURES:

- DESIGN FOR PLC(POWER LINE COMMUNICATION) APPLICATION.
- ROHS COMPLIANT.
- REINFORCED INSULATION
- OPERATING TEMPERATURE RANGE: -40°C TO 85°C.

ELECTRICAL SPECIFICATIONS @25°C					
Part Number	Turns Ratio @100KHz,1V	OCL @100KHz 0.1V	L.L @100KHz 0.1V	DCR @25°C	HI-POT (Pri To Sec)
T1117CA	1-2:3-4:5-6:7-8	1-2,3-4,5-6,7-8	5-8(short1+2+3+4,6+7)	1-2,3-4,5-6,7-8	3000Vrms, 1mA,60S
	1:1:1:1±5%	250uH Min	1.0uH Max	0.4Ω Max	
	CWW@100kHz,1V	Insertion loss @0.5-30MHz	Return loss @0.5-30MHz	IR	
	1-8(short2+3,6+7)			500VDC	
	25pF Max	-1.0dB MAX	-14dB Min	100MΩ MIN	

## MECHANICAL DIMENSIONS

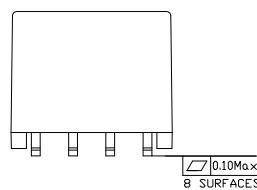
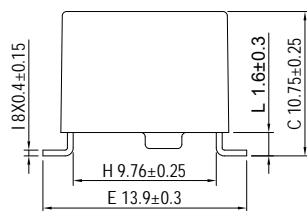
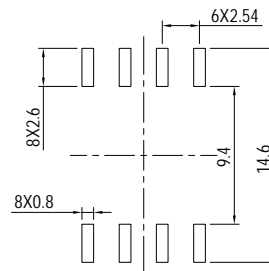
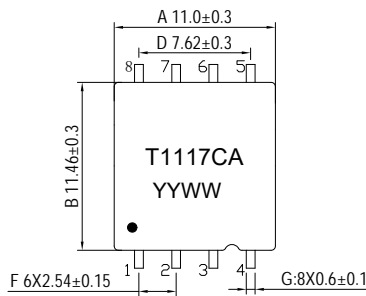

● Unless otherwise specified all tolerances are:±0.25mm

## SCHEMATICS

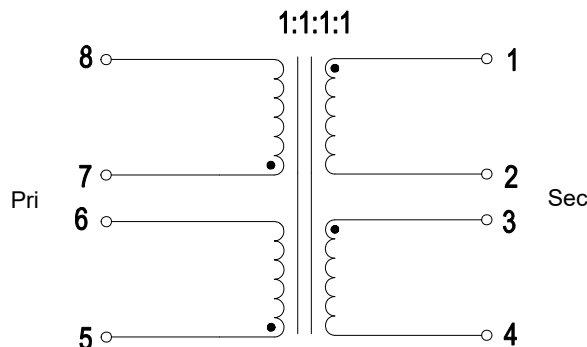

# BROADBAND PLC TRANSFORMER

## T1118CA

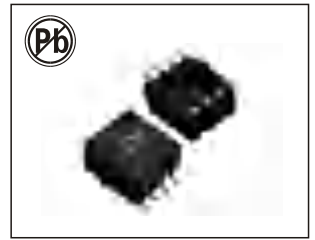

### FEATURES:

- OPERATING TEMPERATURE RANGE: -40 °C TO+125°C
- SURFACE MOUNT DEVICE PROVIDING COMPACT FOOTPRINT
- ROHS COMPLIANT

ELECTRICAL SPECIFICATIONS @25°C						
Part Number	Turns Ratio @100KHz,1V	OCL @100KHz 0.1V	L.L @100KHz 0.1V	DCR @25°C		HI-POT (PLTo TX, TX)
	1-2:3-4:5-6	1-2,3-4,5-6	5-6(short1+2+3+4)	1-2,3-4	5-6	
T1118CA	1:1:1±5%	250uH Min	1.0uH Max	0.4Ω Max	0.5Ω Max	3000Vrms, 1mA,60S
	CWW@100kHz,1V	Insertion loss @0.5-30MHz	Return loss @0.5-30MHz	IR		
	1-5(short2+3)			500VDC		
	15pF Max	-1.0dB MAX	-14dB Min	100MΩ MIN		

## MECHANICAL DIMENSIONS

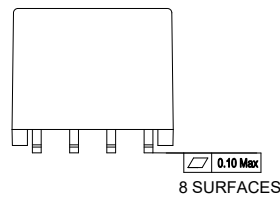
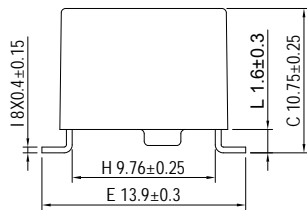
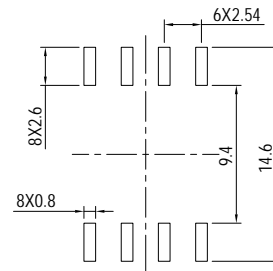
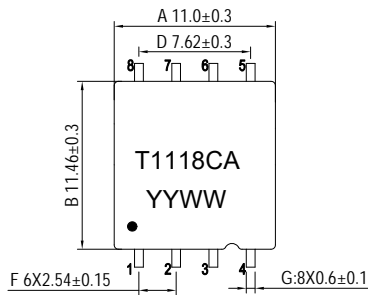

• Unless otherwise specified all tolerances are:±0.25mm

## SCHEMATICS

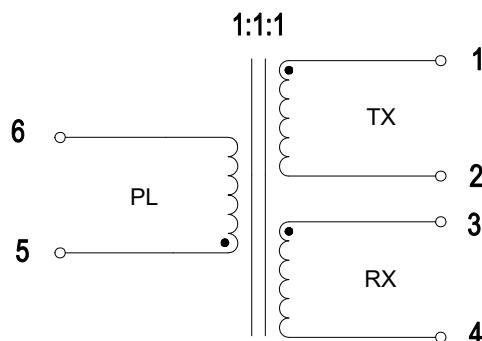

# BROADBAND PLC TRANSFORMER

## T1134CE

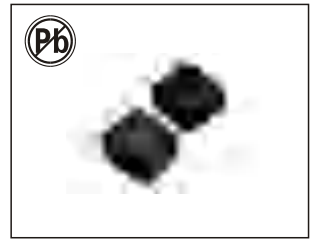

### FEATURES:

- DESIGN FOR PLC(POWER LINE COMMUNICATION) APPLICATION.
- ROHS COMPLIANT.
- REINFORCED INSULATION
- OPERATING TEMPERATURE RANGE: -40°C TO 85°C.

Electrical Specifications @25°C						
Part Number	Turns Ratio @100KHz,0.1V	OCL @100KHz 0.1V	L.L @100KHz 0.1V	DCR @25°C		HI-POT (Pri TO Sec)
	1-2:3-4:5-8	1-2,3-4,5-8	5-8(short1+2+3+4)	1-2,3-4	5-8	
T1134CE	1:1:1±5%	250uH Min	1.0uH Max	0.4Ω Max	0.5Ω Max	3000Vrms, 0.5mA,60S
	CWW@100kHz,1V	Insertion loss @0.5-20MHz	Return loss @0.5-20MHz	IR		
	1-8(short2+3)			500VDC		
	15pF Max	-1.0 dB MAX	-14 dB Min	100MΩ MIN		

### MECHANICAL DIMENSIONS(unit:mm)

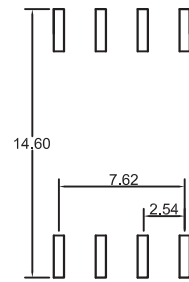
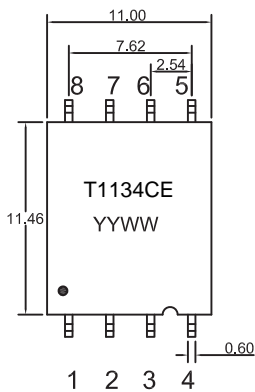

SUGGESTED PAD LAYOUT

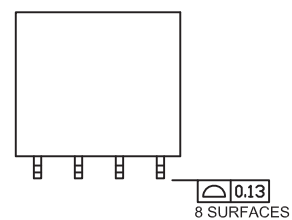

• Unless otherwise specified all tolerances are:±0.25 mm

### SCHEMATICS

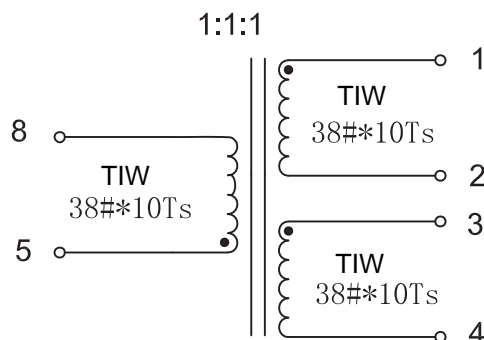

# BROADBAND PLC TRANSFORMER

## T1150CE

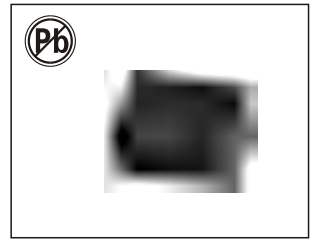

### FEATURES:

- DESIGN FOR PLC(POWER LINE COMMUNICATION) APPLICATION.
- ROHS COMPLIANT.
- REINFORCED INSULATION
- OPERATING TEMPERATURE RANGE: -40°C TO 85°C.

### Electrical Specifications @25°C

Part Number	Turns Ratio @100KHz,0.1V	OCL @100KHz 0.1V	L.L @100KHz 0.1V	IL(	RL	DCR @25°C		HI-POT (Pri TO Sec)
	T1150CE	1-2:3-4:5-8	1-2;3-4;5-8	5-8(short1+2+3+4)	500KHz~20MHz	1-4(short2+3)	5-8	1500Vrms, 0.5mA,60S

### MECHANICAL DIMENSIONS(unit:mm)

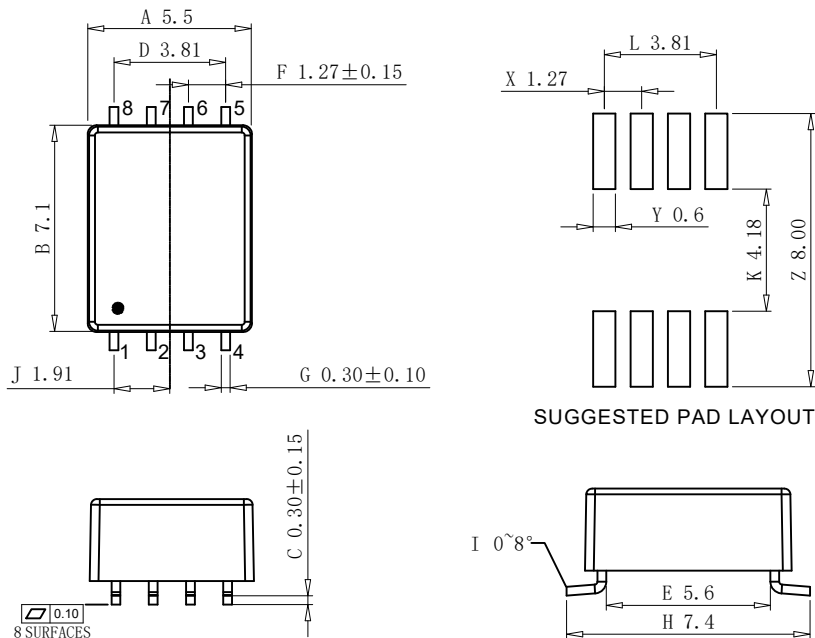

● Unless otherwise specified all tolerances are:±0.25mm

### SCHEMATIC

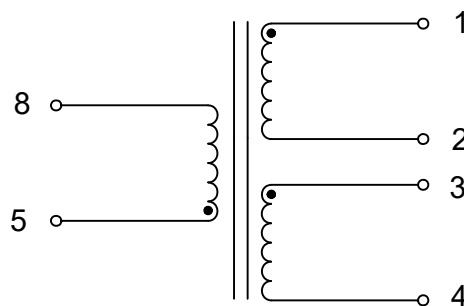

# BROADBAND PLC TRANSFORMER

## T1174CE

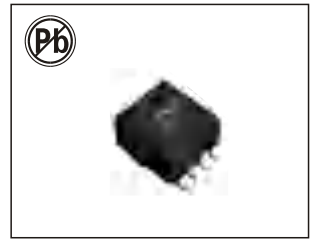

### FEATURES:

- DESIGN FOR PLC(POWER LINE COMMUNICATION) APPLICATION.
- ROHS COMPLIANT.
- REINFORCED INSULATION
- OPERATING TEMPERATURE RANGE: -40°C TO 85°C.

Electrical Specifications @25°C								
Part Number	Turns Ratio (100KHz,1V)	OCL (100KHz,0.1V)	LL (100KHz,0.1V)	Cww (100KHz,0.1V)	DCR	Insertion loss @2-80MHz	Return loss @2-80MHz	Hi-Pot
T1174CE	8-1:2-7:3-6:4-5	8-1,2-7,3-6,4-5	8-1 (tie2-7,3-6,4-5)	1-2 (tie7+3,6+4)	8-1,2-7,3-6,4-5	8-1 To 2-7,3-6,4-5	8-1 To 2-7,3-6,4-5	Pri TO Sec
	1:1:1:1±2%	300uH Min	0.6uH Max	25pF Max	0.5Ω Max	-1.4dB Max	-15dB Min	1500VAC 1.0mA,60S

### MECHANICAL DIMENSIONS(unit:mm)

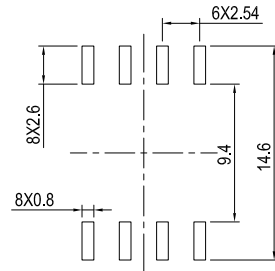
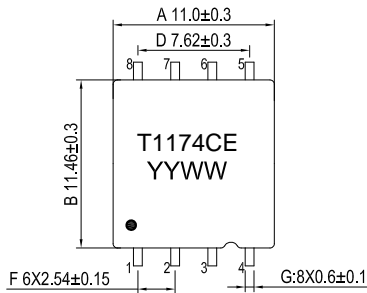

SUGGESTED PAD LAYOUT

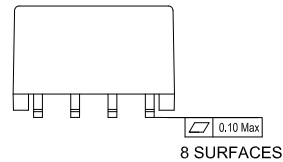
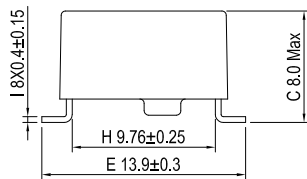

● Unless otherwise specified all tolerances are:±0.25 mm

### SCHEMATICS

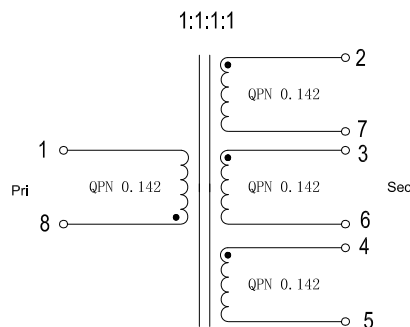



**PACKING:**

Tray:

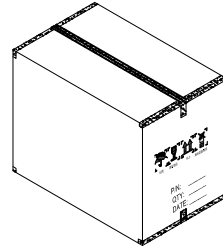
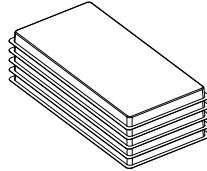
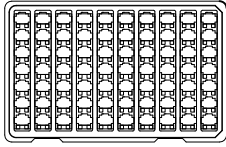

Q'ty

\_\_\_\_\_ PCS Per Tray

\_\_\_\_\_ PCS Per Carton

Tube:

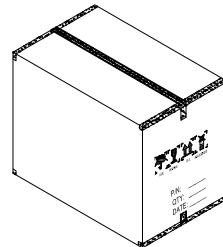
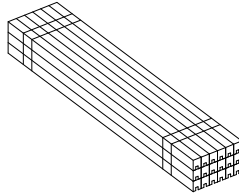
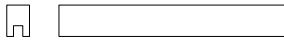

Q'ty

\_\_\_\_\_ PCS Per Tube

\_\_\_\_\_ PCS Per Carton

Reel:

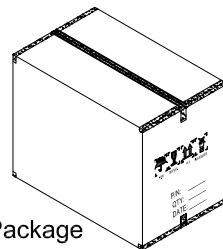
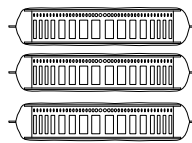
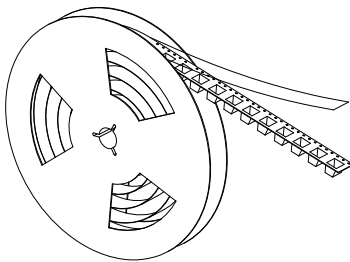

Vacuumize Package

Q'ty

400 PCS Per Reel

2800 PCS Per Carton

**MOISTURE SENSITIVE LEVEL:**

1. Level:1
- 2.Shelf Life:Unlimited
- 3.Storage Condition:≤30°C/85% RH



## RECOMMENDED SOLDERING PROFILE:

### 1. Reflow soldering profile(According to IPC/JEDEC J-STD-020C)

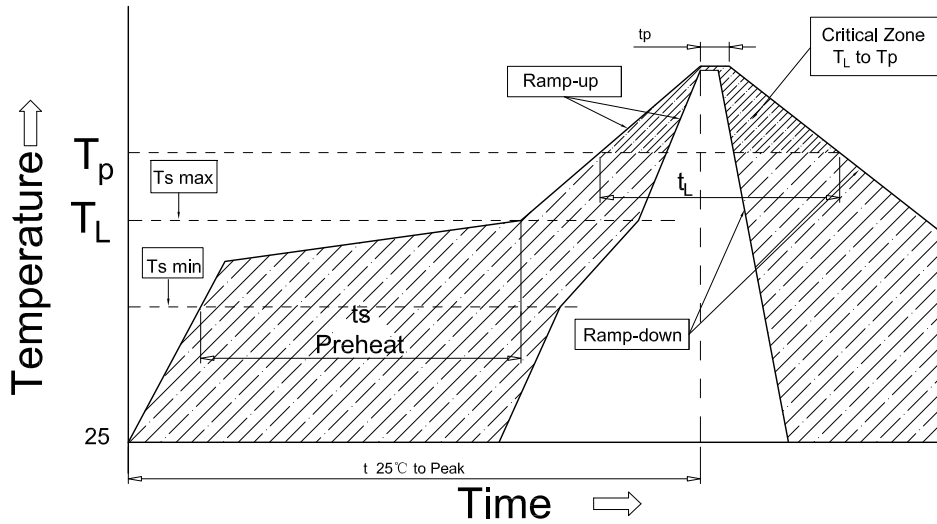

Table 1-1 Classification Reflow Profiles

Profile Feature	Sn-Pb Eutectic Assembly	Pb-Free Assembly
Average Ramp-Up Rate (T <sub>smax</sub> to T <sub>p</sub> )	3°C/second max	3°C/second max
Preheat		
-Temperature Min (T <sub>smin</sub> )	100°C	150°C
-Temperature Max (T <sub>smax</sub> )	150°C	200°C
-Time (t <sub>smin</sub> to t <sub>smax</sub> )	60-120 seconds	60-180 seconds
Time maintained above:	183°C	217°C
-Temperature (T <sub>l</sub> )	60-150 seconds	60-150 seconds
-Time (t <sub>l</sub> )		
Peak/Classification Temperature(T <sub>p</sub> )	See IPC/JEDEC J-STD-020Table 4-1	See IPC/JEDEC J-STD-020Table 4-2
Time within 5°C of actual Peak Temperature(tp)	10-30 seconds	20-40 seconds
Ramp-Down Rate	6°C/second max	6°C/second max
Time 25°C to Peak Temperature	6 minutes max	8 minutes max

Note: All temperatures refer to topside of the package, measured on the package body surface

- Suggested soldering process: Reflow soldering  
Solder Paste: Sn96.5Ag3.0Cu0.5  
Silkscreen thickness: 0.15mm Min.

### 2. Wave soldering profile

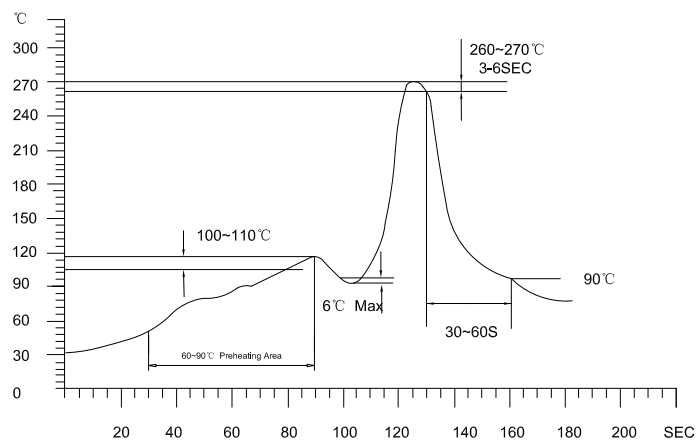

# DUAL BROADBAND PLC TRANSFORMER

## T1175CE

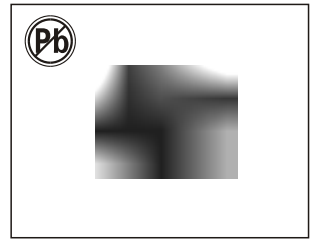

### FEATURES:

- DESIGN FOR PLC(POWER LINE COMMUNICATION) APPLICATION.
- ROHS COMPLIANT.
- REINFORCED INSULATION
- OPERATING TEMPERATURE RANGE: -40°C TO 125°C.

Electrical Specifications @25°C							
Part Number	Turns Ratio @100KHz,1V	OCL @100KHz 0.1V	LK @100KHz 0.1V	DCR @25°C	IL @2MHz-200MHz	RL @2MHz-200MHz	HI-POT (Pri TO Sec)
	1-4:7-8:5-6	1-4,7-8,5-6	1-4(Short 5-6-7-8)	1-4,7-8,5-6	1-4 To 5-6 1-4 To 7-8	1-4 To 5-6 1-4 To 7-8	1500Vrms, 1mA,2S
T1175CE	1:1:1±5%	28uH Min	0.2uH Max	120mΩ Max	2.0dB Max	14.0dB Min	

### MECHANICAL DIMENSIONS(unit:mm)

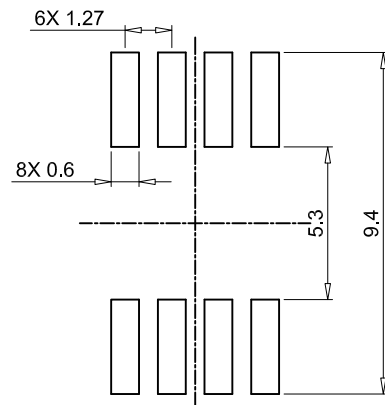
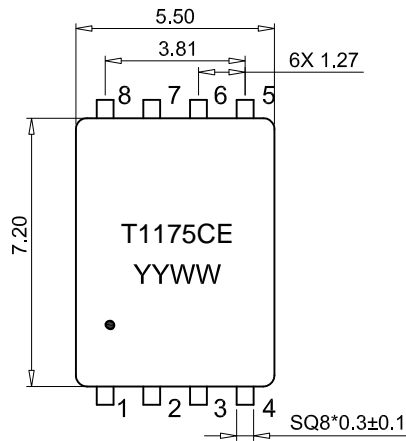

SUGGESTED PAD LAYOUT

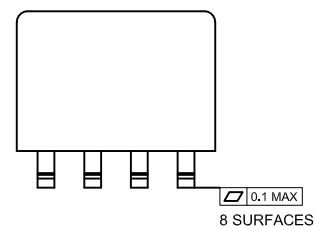
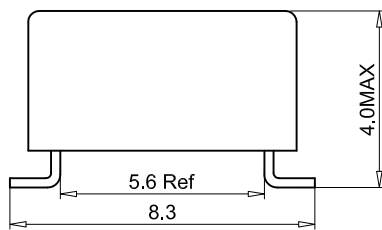

• Unless otherwise specified all tolerances are:±0.25mm

### SCHEMATICS

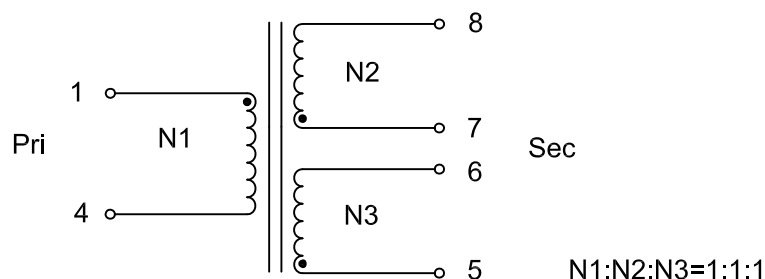

Rev.	Description	Date
A0	New release	2023.05.10

### 1. PHYSICAL CHARACTERISTICS (mm)

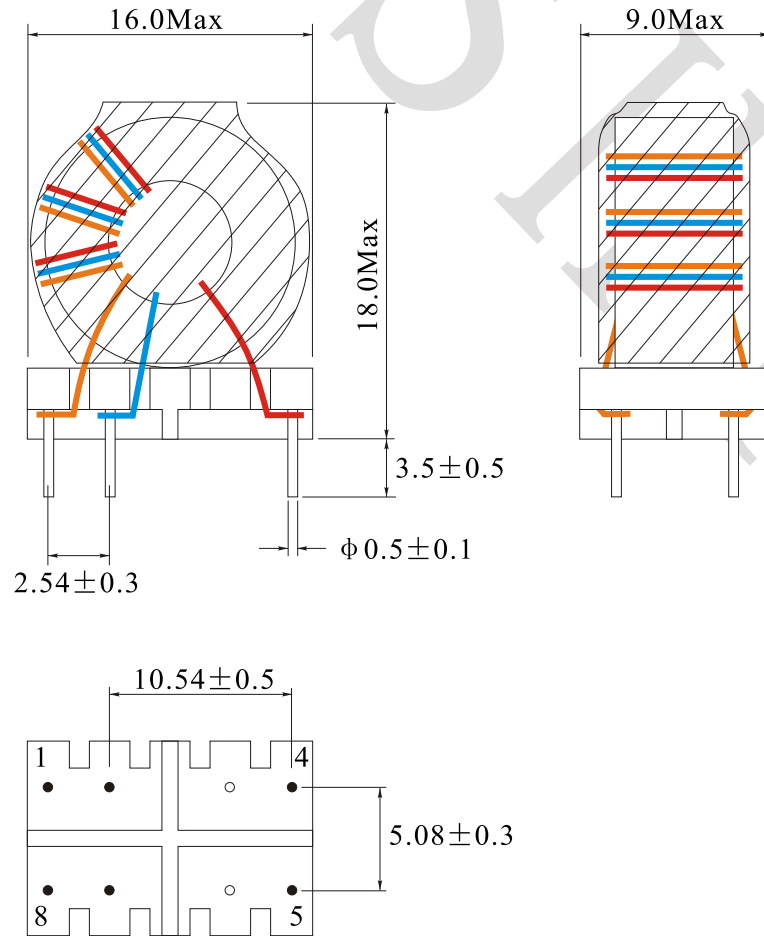

### 2. ELECTRONICAL SCHEMATIC

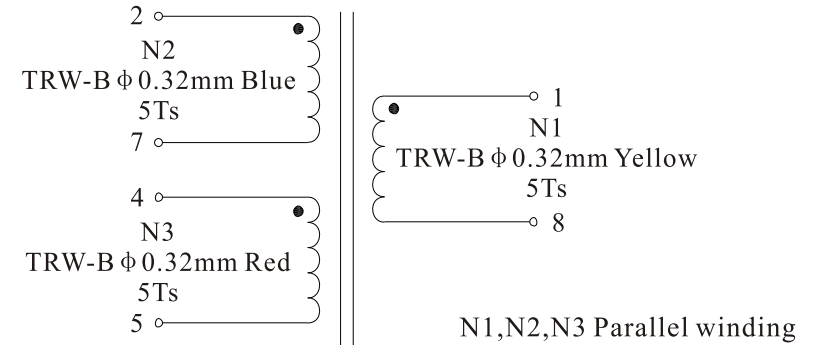

### 3. ELECTRONICAL SPECIFICATIONS

Turns ratio: (1-8):(2-7):(4-5)=1:1:1

Inductance(each winding): 10.9uH±30%@1.0KHz,1V

DCR(each winding): 30mΩ Max

Hi-Pot: 3000Vac,5mA,60S Coil to Core

5600Vac,5mA,60S Pin1,2,7,8 to Pin 4,5

Operating temperature: -40°C to +105°C

Storage temperature: -20°C to +65°C

NAME:	Isolation transformers for broadband PLC system		
CUSTOMER P/N:		DATE:	2023-05-10
SHINHOM P/N:	T1246	REV:	A0
DRAWN BY	CHECKED BY	APPROVE BY	



**SHINHOM**  
SHAANXISHINHOM ENTERPRISE CO LTD

The Document property belong to SHINHOM & is not allowed to be duplicated without authorization

Rev.	Description	Date
A0	New release	2023.05.10

### 1. PHYSICAL CHARACTERISTICS (mm)

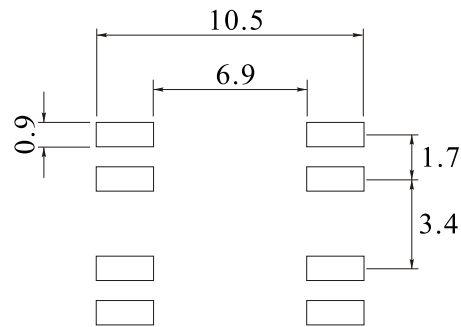
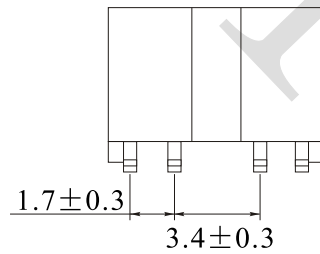
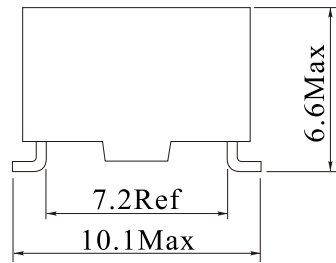
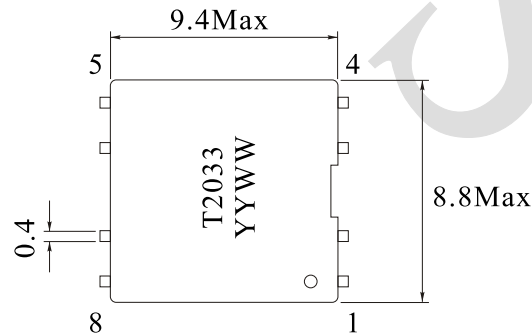

Land pattern

### 2. ELECTRICAL SCHEMATIC

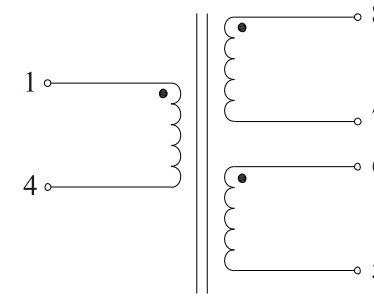

### 3. ELECTRICAL SPECIFICATIONS

Turns ratio: (1-4):(8-7)=1:1

(1-4):(6-5)=3:1

Inductance(1-4): 14.0uH Min@10KHz,0.1V

LK(1-4): 225nH Max@1.0MHz,0.1V, tie other pins

Interwinding capacitance(1-8): 6pF Max, tie 7-6@100KHz,0.1V

DCR(1-4): 0.35 Ω Max

(8-7) 0.3 Ω Max

(6-5) 0.15 Ω Max

Hi-Pot: 3750Vac,0.5mA,1S Pin1-8, tie 7-6

Operating temperature: -40°C to +105°C

Sotrage temperature: -20°C to +65°C

NAME:	Isolation transformers for broadband PLC system		
CUSTOMER P/N:		DATE:	2023-05-10
SHINHOM P/N:	T2033	REV: A0	PAGE
DRAWN BY	CHECKED BY	APPROVE BY	



**SHINHOM**  
SHAANXISHINHOM ENTERPRISE CO LTD

The Document property belong to SHINHOM & is not allowed to be duplicated without authorization

Rev.	Description	Date
A0	New release	2023.05.10

### 1. PHYSICAL CHARACTERISTICS (mm)

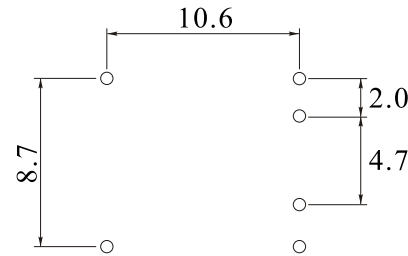
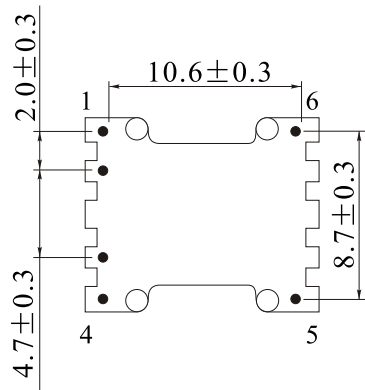
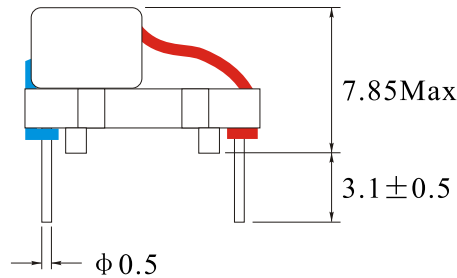
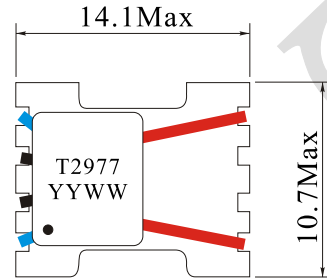

Land pattern

### 2. ELECTRONICAL SCHEMATIC

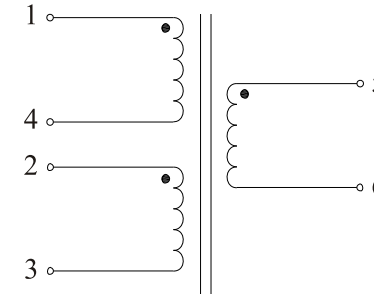

### 3. ELECTRONICAL SPECIFICATIONS

Turns ratio: (2-3):(1-4):(5-6)=1:5:4 ± 5% @ 50KHz

Inductance(2-3): 1.3uH Typ@2MHz,0.1V

(1-4): 34.7uH Typ@2MHz,0.1V

(5-6): 22.2uH Typ@2MHz,0.1V

LK(2-3): 15nH Typ@2MHz,0.1V, Short other pins

Hi-Pot: 3750Vac,1mA,2S between windings

Operating temperature: -40°C to +105°C

Storage temperature: -20°C to +65°C

NAME:		Isolation transformers for broadband PLC system	
CUSTOMER P/N:		DATE:	2023-05-10
SHINHOM P/N:		T2977	REV: A0
DRAWN BY:		CHECKED BY:	APPROVE BY:



**SHINHOM**  
SHAANXISHINHOM ENTERPRISE CO LTD

The Document property belong to SHINHOM & is not allowed to be duplicated without authorization

Rev.	Description	Date
A0	New release	2023.12.29

### 1. PHYSICAL CHARACTERISTICS (mm)

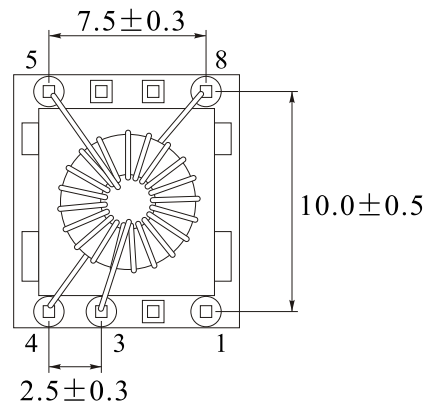
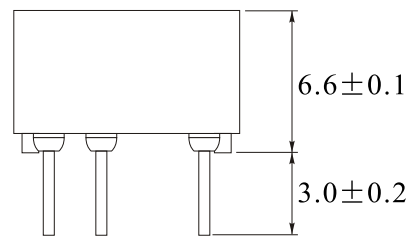
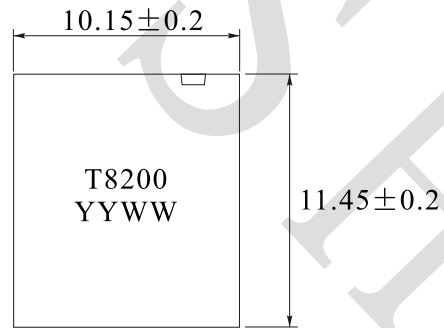

### 2. ELECTRICAL SCHEMATIC

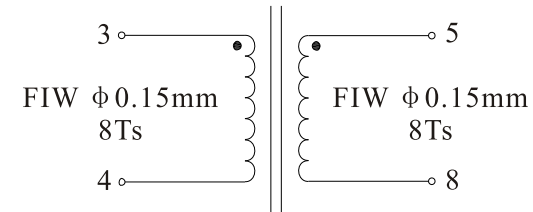

### 3. ELECTRICAL SPECIFICATIONS

Turns ratio: (3-4):(5-8)=1:1

Inductance(3-4): 20.0uH Min@2.5MHz,0.1V

LK(3-4): 0.3uH Max@2.5MHz,0.1V, tie 5-8

Interwinding capacitance(4-5): 5pF Max@2.5MHz,0.1V

DCR(3-4): 96mΩ Max

(5-8) 96mΩ Max

Hi-Pot: 5000Vac,1mA,60S

Operating temperature: -40°C to +75°C

(Including self-temp. rise)

Sotrage temperature: -40°C to +85°C

NAME:	Isolation transformers for broadband PLC system		
CUSTOMER P/N:		DATE:	2023-12-29
SHINHOM P/N:	T8200	REV: A0	PAGE
DRAWN BY	CHECKED BY	APPROVE BY	



**SHINHOM**  
SHAANXISHINHOM ENTERPRISE CO LTD

The Document property belong to SHINHOM & is not allowed to be duplicated without authorization

Rev.	Description	Date
A0	New release	2023.12.29

### 1. PHYSICAL CHARACTERISTICS (mm)

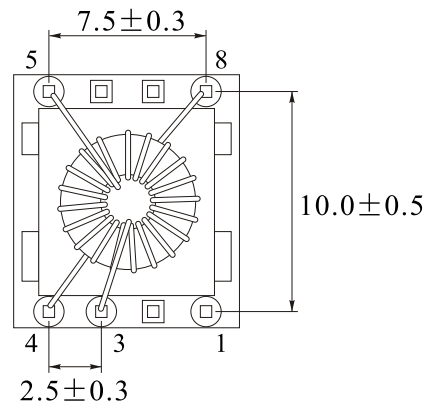
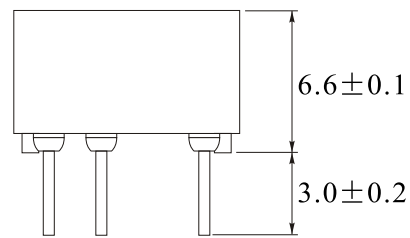
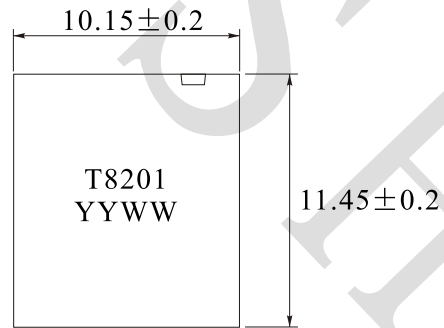

### 2. ELECTRICAL SCHEMATIC

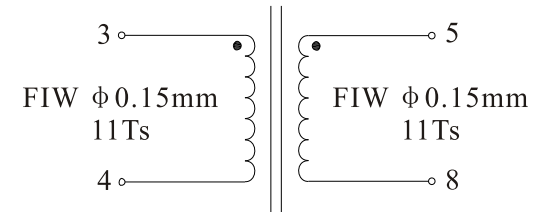

### 3. ELECTRICAL SPECIFICATIONS

Turns ratio: (3-4):(5-8)=1:1

Inductance(3-4): 200uH Min@100KHz,0.1V

LK(3-4): 1.0uH Max@100KHz,0.1V, tie 5-8

DCR(3-4): 160mΩ Max

(5-8) 160mΩ Max

Hi-Pot: 5000Vac,1mA,60S

Operating temperature: -40°C to +75°C

(Including self-temp. rise)

Storage temperature: -40°C to +85°C

NAME:	Isolation transformers for broadband PLC system		
CUSTOMER P/N:		DATE:	2023-12-29
SHINHOM P/N:	T8201	REV: A0	PAGE
DRAWN BY	CHECKED BY	APPROVE BY	



**SHINHOM**  
SHAANXISHINHOM ENTERPRISE CO LTD

The Document property belong to SHINHOM & is not allowed to be duplicated without authorization

Rev.	Description	Date
A0	New release	2023.12.29

### 1. PHYSICAL CHARACTERISTICS (mm)

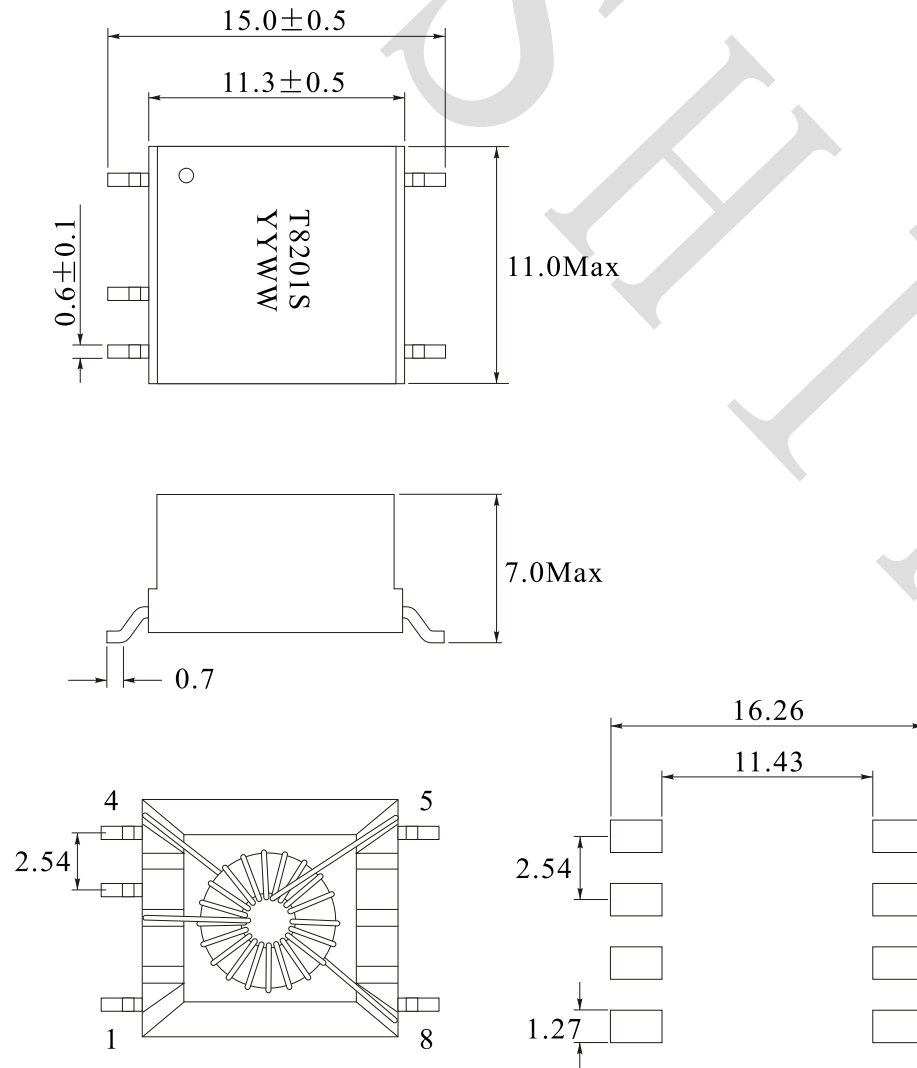

### 2. ELECTRICAL SCHEMATIC

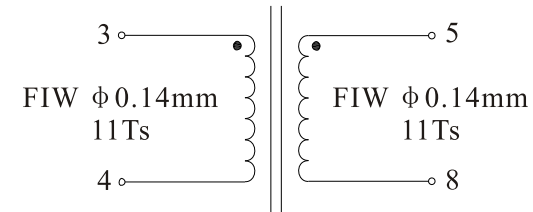

### 3. ELECTRICAL SPECIFICATIONS

Turns ratio: (3-4):(5-8)=1:1

Inductance(3-4): 200uH Min@100KHz,0.1V

LK(3-4): 1.0uH Max@100KHz,0.1V, tie 5-8

DCR(3-4): 134mΩ Max

(5-8) 134mΩ Max

Hi-Pot: 5000Vac,1mA,60S

Operating temperature: -40°C to +75°C

(Including self-temp. rise)

Storage temperature: -40°C to +85°C

NAME:		Isolation transformers for broadband PLC system	
CUSTOMER P/N:		DATE:	2023-12-29
SHINHOM P/N:		T8201S	REV: A0
DRAWN BY:		CHECKED BY:	APPROVE BY:



**SHINHOM**  
SHAANXISHINHOM ENTERPRISE CO LTD

The Document property belong to SHINHOM & is not allowed to be duplicated without authorization

# BROADBAND PLC TRANSFORMER

## T953DG



### FEATURES:

- DESIGN FOR PLC(POWER LINE COMMUNICATION) APPLICATION.
- ROHS COMPLIANT.
- REINFORCED INSULATION
- OPERATING TEMPERATURE RANGE: -40°C TO 85°C.

### Electrical Specifications @25°C

Part Number	OCV @10KHz,0.25V	OCV @10KHz,0.25V	DCR @25°C	DCR @25°C	Turns Ration @1kHz,0.25V	Hi-Pot
	1-6=2-5	3-4	1-6=2-5	3-4	1-6:2-5:3-4	1-6 TO 2-5,3-4
T953DG	93-209uH	23-52uH	120mΩ Max	80mΩ Max	1:1:0.5±3%	3000Vac,3mA,60S,60Hz

### MECHANICAL

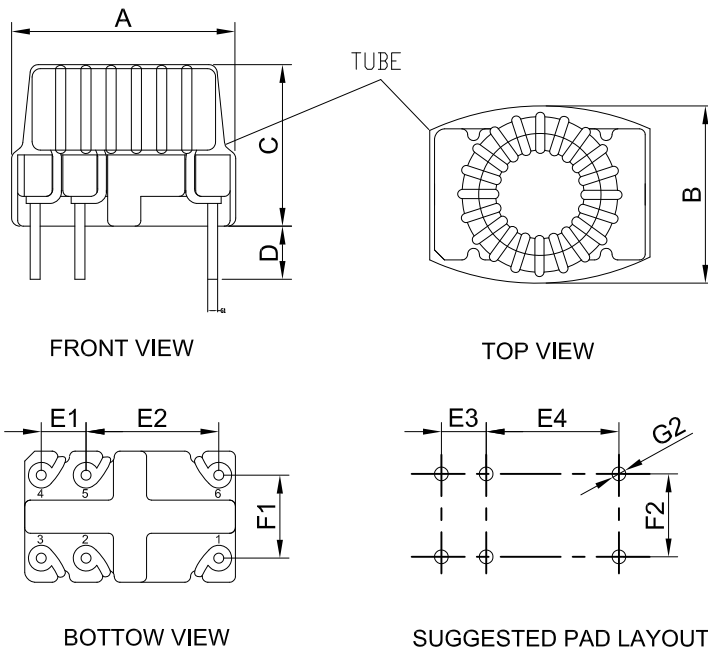

DIM	MILLIMETERS (Units:mm)
A	14.0 Max
B	12.5 Max
C	11.5 Max
D	3.0±0.5
E1	2.7±0.5
E2	8.0±0.3
F1	5.0±0.5
G1	0.6±0.1
E3	2.7 Typ
E4	8.0 Typ
F2	5.0 Typ
G2	1.2 Typ

### SCHEMATICS

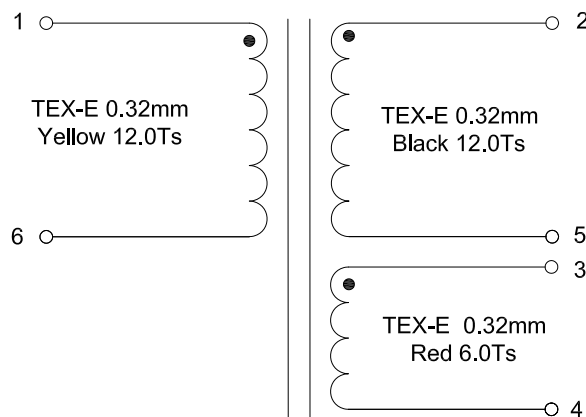

# ISOLATION TRANSFORMERS FOR NARROWBAND PLC SYSTEMS

## GT70 Series

### FEATURES:

- Excellent transmission characteristics
- High mains current capability, low THD
- Matching with all leading IC (modulation methods FSK, DCSK and OFDM)
- Compliant with all PLC standards (HomePlug, CENELEC ...)
- Compact designs in THT and SMT housings
- Insulation according to IEC 60950, UL 1950 and IEC 61558

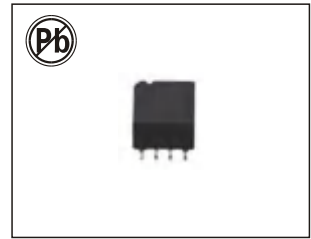

### DESCRIPTION:

For narrowband PLC systems where the operating frequency may be up to 500 kHz isolation transformers based on amorphous or nanocrystalline offer excellent transmission characteristics, high robustness against EMC interferences and safe galvanic insulation.

### STANDARD SPECIFICATION:

Part Number	Turns ratio	Sec. current (mA)Max	Sec. Inductance (mH)Min	Sec. Leakage inductance (Short Pri.) (uH)	Capacitance Pri to Sec (pF)Typ.	Sec. DCR (Ω)Typ.	Insulation voltage Pri. to Sec. (V)	Hi-Pot (kV)
GT7001	1:1:2	100	0.7	1	40	0.5	400	4.0
GT7002	1:1:2	35	0.88	0.4	30	0.1	400	3.0
GT7003	1:1	30	1.4	0.3	25	0.2	250	5.5
GT7004	1:1	15	2.5	0.9	50	0.3	250	3.0
GT7005	2:1	30	1.4	0.5	50	0.12	400	3.0
GT7006	1.68:1	50	0.43	6	17	0.17	100	1.5
GT7007	1:1:2	100	0.7	1	40	0.5	400	3.0
GT7008	1:4:4	30	1.56	1	25	0.15	400	3.0

### PHYSICAL CHARACTERISTICS

### TECHNICAL INFORMATION:

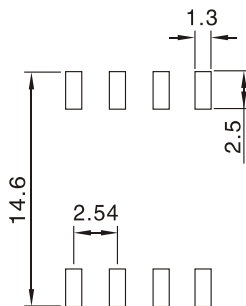
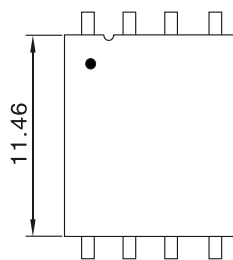
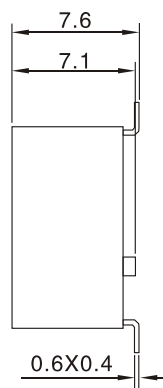
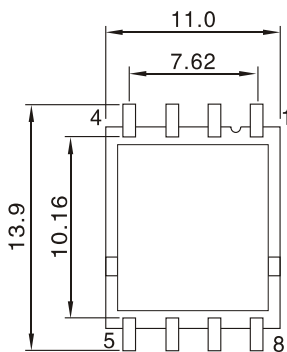

Winding 1

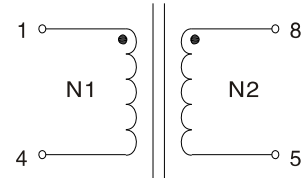

Winding 2

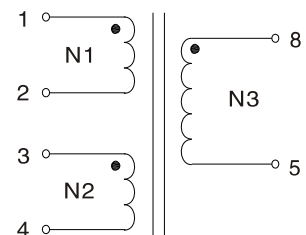

# PUSH-PULL ISOLATION TRANSFORMER ST764 SERIES



## Features

- Low profile and small size
- Designed to comply with IEC 62368
- RoHS compliant

## Applications

- Isolated RS-485/RS-232 power supplies
- Industrial automation
- AC motor drives
- Smart metering
- Solar inverters

## ELECTRICAL CHARACTERISTICS:@25°C

Part Number	Primary Inductance @ 100 kHz / 0.1 V ± 10%(uH)	Turns Ratio	Volt Microseconds Max. V-uS	DCR Max. (m Ω )	DCR Max. (m Ω )	Isolation Voltage (Volts RMS)
	(1-3)	(1-3) : (6-4)	(1-3)	(1-3)	(6-4)	(1-3) : (6-4)
ST764117	475	1:1.7	11	650	900	3100
ST764120	475	1:2	11	650	1000	3100
ST764111	475	1:1.1	11	650	700	3100
ST764113	475	1:1.3	11	650	800	3100

## PHYSICAL CHARACTERISTICS:(mm) LAYOUT:

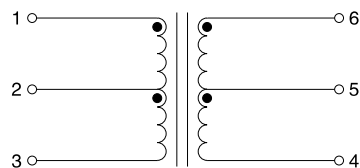
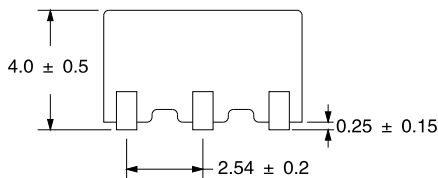
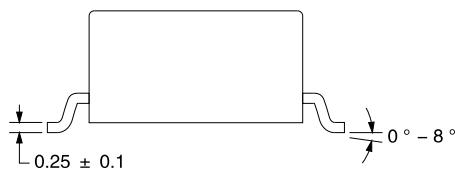
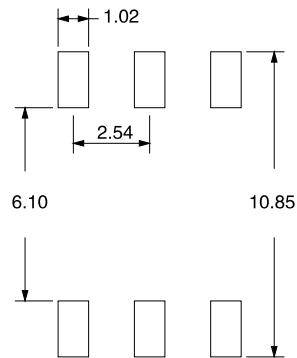
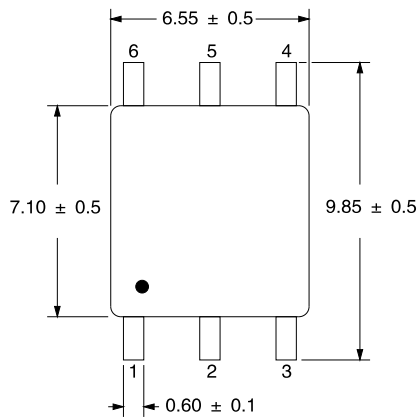

Operating Temperature .....-40 °C to +125 °C  
 Storage Temperature (with packaging) .....-10 °C to +40 °C  
 Storage Temperature (without packaging) .....-40 °C to +125 °C  
 Current Rating .....350 mArms  
 HI-POT Pri / Sec .....3100 VAC / 1 mA / 2 s  
 Level of Insulation.....Functional insulation for a working voltage of 400 Vrms  
 per IEC 62368

**SOLDERING PROFILE:**

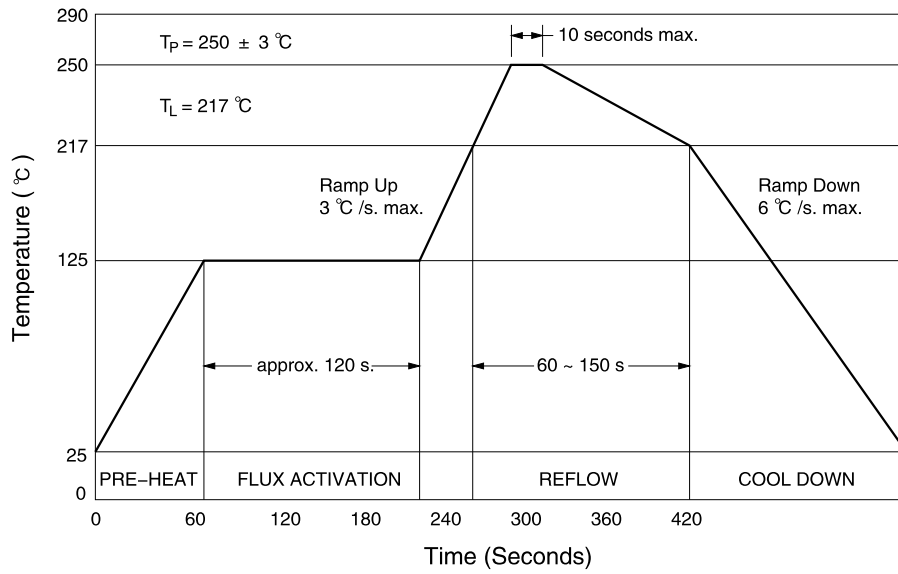

Time within 5 °C of actual Peak Temperature (tp) .....20 ~ 40 s.  
 Ts min. ....150 °C  
 Ts max. ....200 °C  
 Ts min. to Ts max. ....60 ~ 180 s.  
 25 °C to Peak Temperature .....8 minutes max.

**PACKAGING SPECIFICATIONS:(mm)**

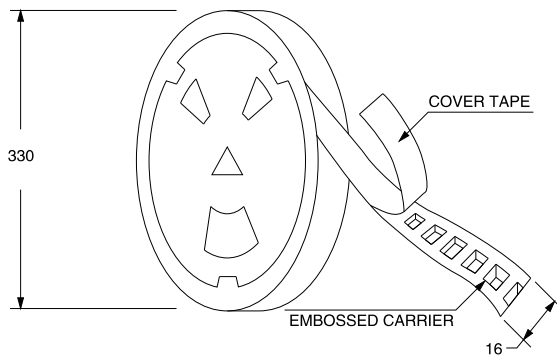
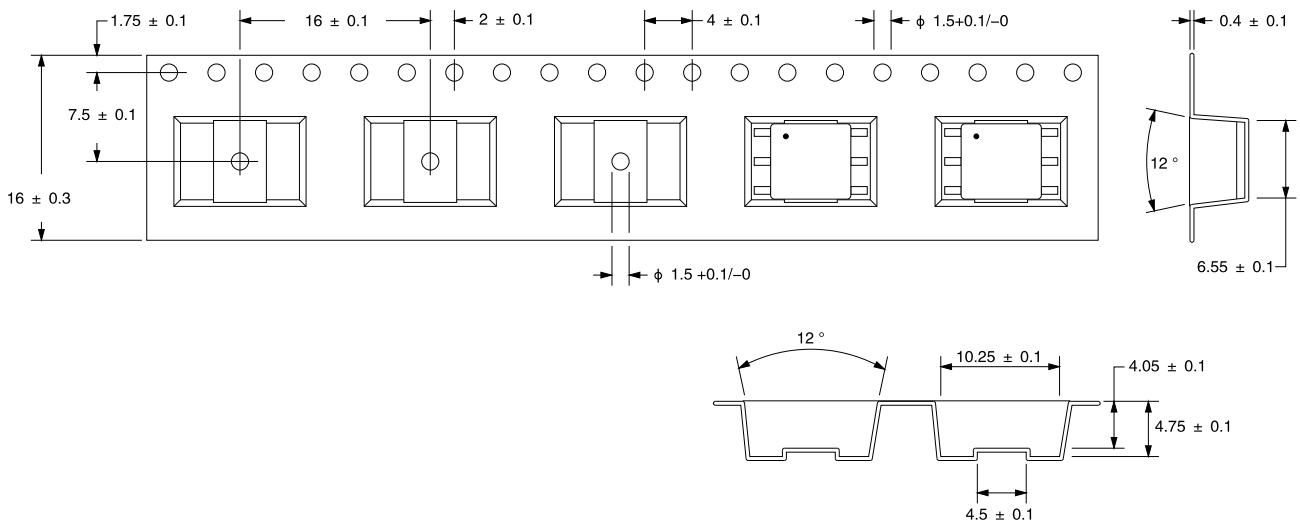

800 pcs. per 13-inch reel

# ISOLATION TRANSFORMERS FOR NARROWBAND PLC SYSTEMS

## T4021 Series

### FEATURES:

- Excellent transmission characteristics
- High mains current capability, low THD
- Matching with all leading IC (modulation methods FSK, DCSK and OFDM)
- Compliant with all PLC standards (HomePlug, CENELEC ...)
- Compact designs in THT and SMT housings
- Insulation according to IEC 60950, UL 1950 and IEC 61558

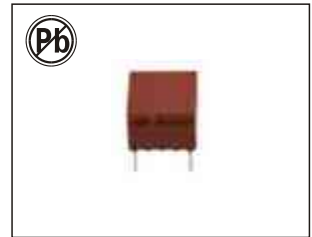

### DESCRIPTION:

For narrowband PLC systems where the operating frequency may be up to 500 kHz isolation transformers based on amorphous or nanocrystalline offer excellent transmission characteristics, high robustness against EMC interferences and safe galvanic insulation.

### STANDARD SPECIFICATION:

Part Number	Turns ratio	Sec. current (mA)Max	Sec. Inductance (mH)Min	Sec. Leakage inductance (Short Pri.) (uH)	Capacitance Pri to Sec (pF)Typ.	Sec. DCR (Ω)Typ.	Insulation voltage Pri. to Sec. (V)	Hi-Pot (kV)
T4021-142	1.68:1	50	0.43	6	17	0.17	100	1.5
T4021-144	1.37:1	120	0.43	1	35	0.22	450	5.1
T4021-145	1.7:1	130	0.34	1	30	0.2	450	5.1
T4021-146	1:1	100	0.68	1	35	0.26	450	5.1

### PHYSICAL CHARACTERISTICS

### TECHNICAL INFORMATION:

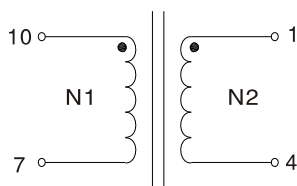
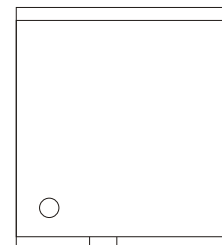
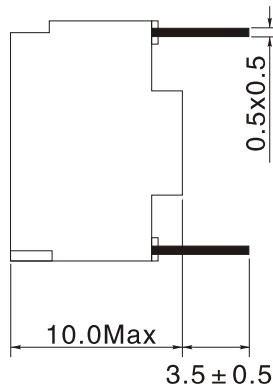
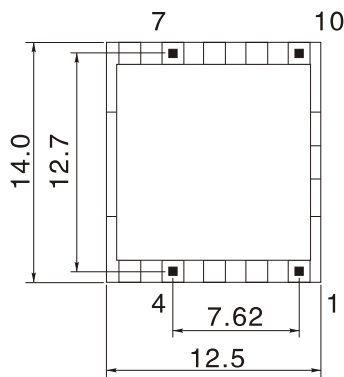

#### Notes:

- Electrical specification at 25°C
- Testing: LCR Bridge measured @ 1KHz 0.1V HP 4284A (Equivalent acceptable)
- RDC: QuadTech 1880 Milliohm meter
- Operating temperature rang: -40°C to +125°C
- Storage temperature rang: -40°C to +125°C

Note: All specifications subject to change without notice.

# ISOLATION TRANSFORMERS FOR NARROWBAND PLC SYSTEMS

## T4031 Series

### FEATURES:

- Excellent transmission characteristics
- High mains current capability, low THD
- Matching with all leading IC (modulation methods FSK, DCSK and OFDM)
- Compliant with all PLC standards (HomePlug, CENELEC ...)
- Compact designs in THT and SMT housings
- Insulation according to IEC 60950, UL 1950 and IEC 61558

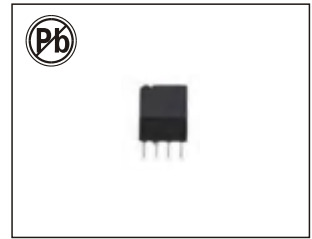

### DESCRIPTION:

For narrowband PLC systems where the operating frequency may be up to 500 kHz isolation transformers based on amorphous or nanocrystalline offer excellent transmission characteristics, high robustness against EMC interferences and safe galvanic insulation.

### STANDARD SPECIFICATION:

Part Number	Turns ratio	Sec. current (mA)Max	Sec. Inductance (mH)Min	Sec. Leakage inductance (Short Pri.) (uH)	Capacitance Pri to Sec (pF)Typ.	Sec. DCR (Ω)Typ.	Insulation voltage Pri. to Sec. (V)	Hi-Pot (kV)
T4031-009	2:1	5	1.0	0.17	17	0.08	300	4.2

### PHYSICAL CHARACTERISTICS

### TECHNICAL INFORMATION:

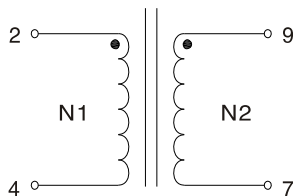
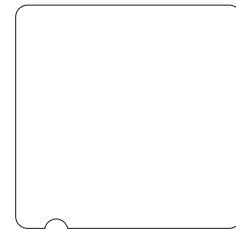
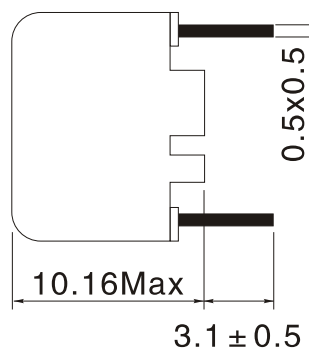
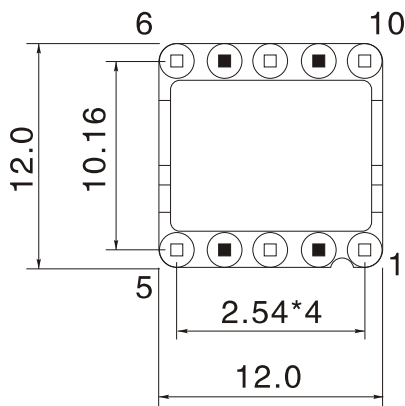

#### Notes:

Electrical specification at 25°C

Testing: LCR Bridge measured @ 1KHz 0.1V HP 4284A

(Equivalent acceptable)

RDC: QuadTech 1880 Milliohmmeter

Operating temperature rang: -40°C to +125°C

Storage temperature rang: -40°C to +125°C

Note: All specifications subject to change without notice.

# ISOLATION TRANSFORMERS FOR NARROWBAND PLC SYSTEMS

## T4081 Series

### FEATURES:

- Excellent transmission characteristics
- High mains current capability, low THD
- Matching with all leading IC (modulation methods FSK, DCSK and OFDM)
- Compliant with all PLC standards (HomePlug, CENELEC ...)
- Compact designs in THT and SMT housings
- Insulation according to IEC 60950, UL 1950 and IEC 61558

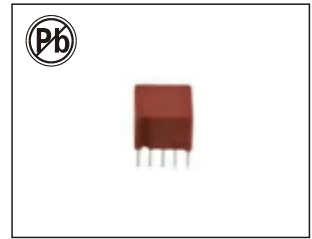

### DESCRIPTION:

For narrowband PLC systems where the operating frequency may be up to 500 kHz isolation transformers based on amorphous or nanocrystalline offer excellent transmission characteristics, high robustness against EMC interferences and safe galvanic insulation.

### STANDARD SPECIFICATION:

Part Number	Turns ratio	Sec. current (mA)Max	Sec. Inductance (mH)Min	Sec. Leakage inductance (Short Pri.) (uH)	Capacitance Pri to Sec (pF)Typ.	Sec. DCR (Ω)Typ.	Insulation voltage Pri. to Sec. (V)	Hi-Pot (kV)
T4081-004	1:1	30	1.4	0.8	25	0.2	400	4.0
T4081-007	2:1	35	0.9	0.3	25	0.11	250	5.5
T4081-008	1.36:1	32	1.2	0.4	25	0.13	250	5.5

### PHYSICAL CHARACTERISTICS

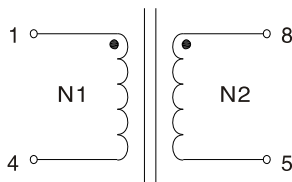
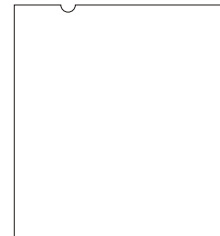
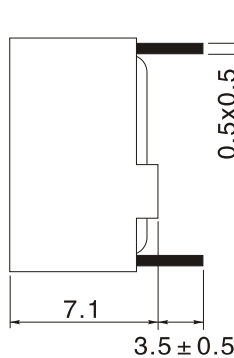
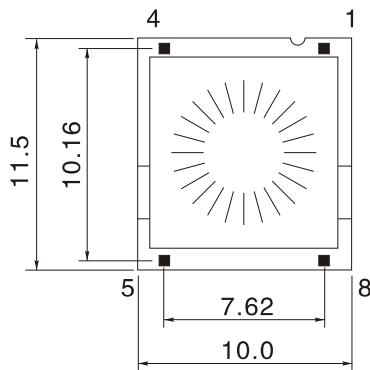

#### Notes:

- Electrical specification at 25°C
- Testing: LCR Bridge measured @ 1KHz 0.1V HP 4284A (Equivalent acceptable)
- RDC: QuadTech 1880 Milliohm meter
- Operating temperature rang: -40°C to +125°C
- Storage temperature rang: -40°C to +125°C

Note: All specifications subject to change without notice.

# ISOLATION TRANSFORMERS FOR NARROWBAND PLC SYSTEMS

## T4085 Series

### FEATURES:

- Excellent transmission characteristics
- High mains current capability, low THD
- Matching with all leading IC (modulation methods FSK, DCSK and OFDM)
- Compliant with all PLC standards (HomePlug, CENELEC ...)
- Compact designs in THT and SMT housings
- Insulation according to IEC 60950, UL 1950 and IEC 61558

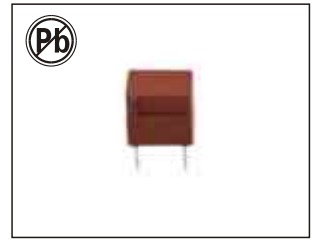

### DESCRIPTION:

For narrowband PLC systems where the operating frequency may be up to 500 kHz isolation transformers based on amorphous or nanocrystalline offer excellent transmission characteristics, high robustness against EMC interferences and safe galvanic insulation.

### STANDARD SPECIFICATION:

Part Number	Turns ratio	Sec. current (mA)Max	Sec. Inductance (mH)Min	Sec. Leakage inductance (Short Pri.) (uH)	Capacitance Pri to Sec (pF)Typ.	Sec. DCR (Ω)Typ.	Insulation voltage Pri. to Sec. (V)	Hi-Pot (kV)
T4085-004	1:1	30	1.4	0.8	25	0.2	300	4.0

### PHYSICAL CHARACTERISTICS

### TECHNICAL INFORMATION:

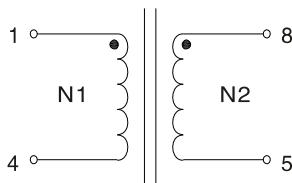
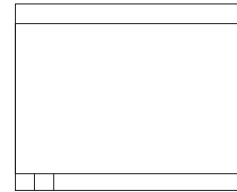
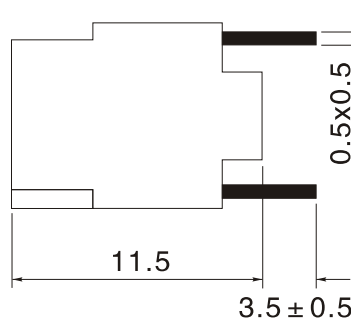
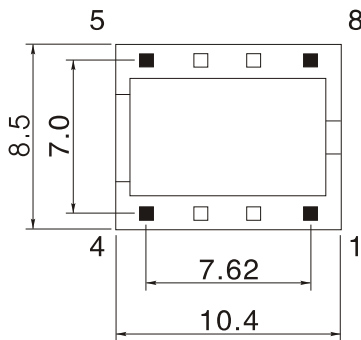

#### Notes:

Electrical specification at 25°C

Testing: LCR Bridge measured @ 1KHz 0.1V HP 4284A (Equivalent acceptable)

RDC: QuadTech 1880 Milliohmmeter

Operating temperature rang: -40°C to +125°C

Storage temperature rang: -40°C to +125°C

Note: All specifications subject to change without notice.

# ISOLATION TRANSFORMERS FOR NARROWBAND PLC SYSTEMS

## T4096 Series

### FEATURES:

- Excellent transmission characteristics
- High mains current capability, low THD
- Matching with all leading IC (modulation methods FSK, DCSK and OFDM)
- Compliant with all PLC standards (HomePlug, CENELEC ...)
- Compact designs in THT and SMT housings
- Insulation according to IEC 60950, UL 1950 and IEC 61558

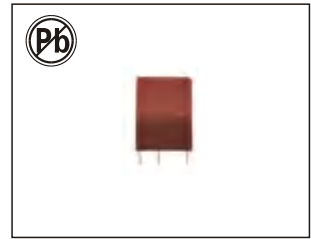

### DESCRIPTION:

For narrowband PLC systems where the operating frequency may be up to 500 kHz isolation transformers based on amorphous or nanocrystalline offer excellent transmission characteristics, high robustness against EMC interferences and safe galvanic insulation.

### STANDARD SPECIFICATION:

Part Number	Turns ratio	Sec. current (mA)Max	Sec. Inductance (mH)Min	Sec. Leakage inductance (Short Pri.) (uH)	Capacitance Pri to Sec (pF)Typ.	Sec. DCR (Ω)Typ.	Insulation voltage Pri. to Sec. (V)	Hi-Pot (kV)
T4096-046	1:1	30	1.3	1	12	0.15	500	6.0
T4096-047	1:1	/	1.3	10	5	0.2	500	6.0

### PHYSICAL CHARACTERISTICS

### TECHNICAL INFORMATION:

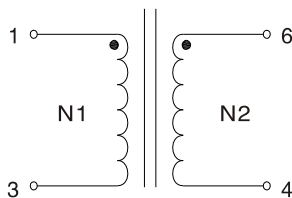
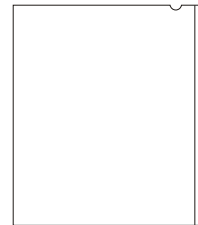
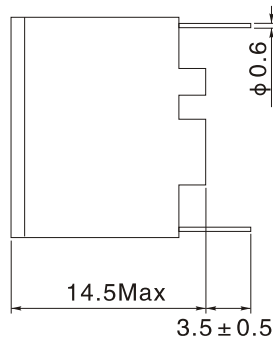
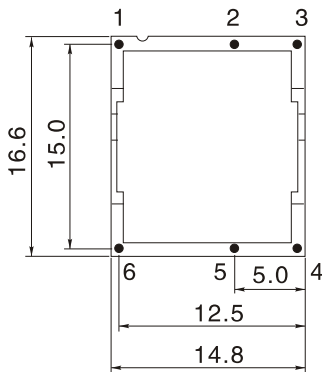

Notes:

- Electrical specification at 25°C
- Testing:LCR Bridge measured @ 1KHz 0.1V HP 4284A (Equivalent acceptable)
- RDC: QuadTech 1880 Milliohm meter
- Operating temperature rang: -40°C to +125°C
- Storage temperature rang: -40°C to +125°C

Note:All specifications subject to change without notice.

# ISOLATION TRANSFORMERS FOR NARROWBAND PLC SYSTEMS

## T4185 Series

### FEATURES:

- Excellent transmission characteristics
- High mains current capability, low THD
- Matching with all leading IC (modulation methods FSK, DCSK and OFDM)
- Compliant with all PLC standards (HomePlug, CENELEC ...)
- Compact designs in THT and SMT housings
- Insulation according to IEC 60950, UL 1950 and IEC 61558

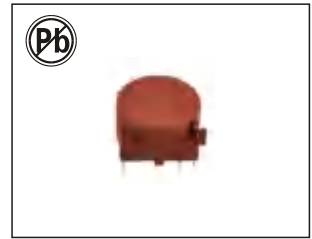

### DESCRIPTION:

For narrowband PLC systems where the operating frequency may be up to 500 kHz isolation transformers based on amorphous or nanocrystalline offer excellent transmission characteristics, high robustness against EMC interferences and safe galvanic insulation.

### STANDARD SPECIFICATION:

Part Number	Turns ratio	Sec. current (mA)Max	Sec. Inductance (mH)Min	Sec. Leakage inductance (Short Pri.) (uH)	Capacitance Pri to Sec (pF)Typ.	Sec. DCR (Ω)Typ.	Insulation voltage Pri. to Sec. (V)	Hi-Pot (kV)
T4185-047	1:1	50	1.4	0.8	15	0.2	400	10.0

### PHYSICAL CHARACTERISTICS

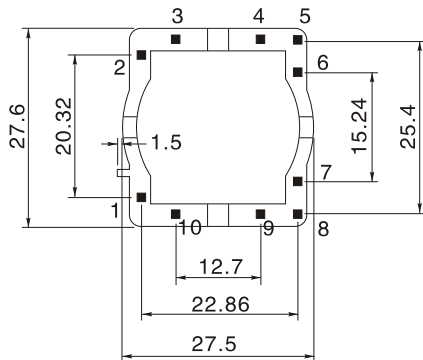

### TECHNICAL INFORMATION:

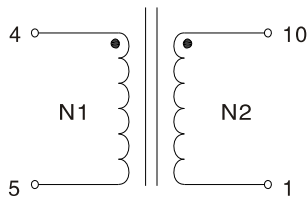
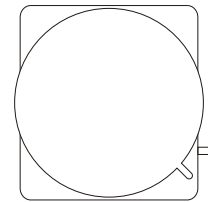
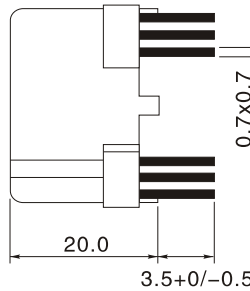

#### Notes:

Electrical specification at 25°C

Testing: LCR Bridge measured @ 1KHz 0.1V HP 4284A (Equivalent acceptable)

RDC: QuadTech 1880 Milliohm meter

Operating temperature rang: -40°C to +125°C

Storage temperature rang: -40°C to +125°C

Note: All specifications subject to change without notice.

# ISOLATION TRANSFORMERS FOR NARROWBAND PLC SYSTEMS

## T4614 Series

### FEATURES:

- Excellent transmission characteristics
- High mains current capability, low THD
- Matching with all leading IC (modulation methods FSK, DCSK and OFDM)
- Compliant with all PLC standards (HomePlug, CENELEC ...)
- Compact designs in THT and SMT housings
- Insulation according to IEC 60950, UL 1950 and IEC 61558

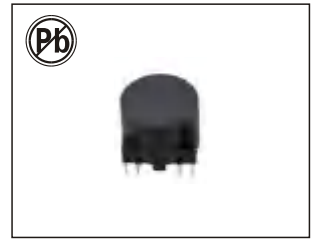

### DESCRIPTION:

For narrowband PLC systems where the operating frequency may be up to 500 kHz isolation transformers based on amorphous or nanocrystalline offer excellent transmission characteristics, high robustness against EMC interferences and safe galvanic insulation.

### STANDARD SPECIFICATION:

Part Number	Turns ratio	Sec. current (mA)Max	Sec. Inductance (mH)Min	Sec. Leakage inductance (Short Pri.) (uH)	Capacitance Pri to Sec (pF)Typ.	Sec. DCR (Ω)Typ.	Insulation voltage Pri. to Sec. (V)	Hi-Pot (kV)
T4614-010	1:1.2	250	0.44	0.9	60	0.02	450	5.1

### PHYSICAL CHARACTERISTICS

### TECHNICAL INFORMATION:

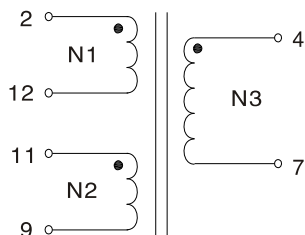
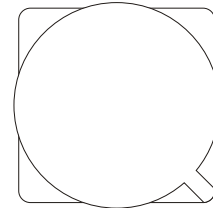
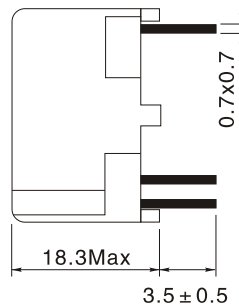
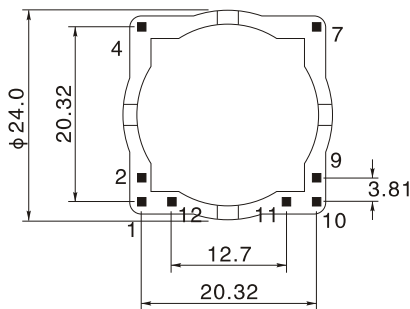

Notes:

Electrical specification at 25°C

Testing: LCR Bridge measured @ 1KHz 0.1V HP 4284A

(Equivalent acceptable)

RDC: QuadTech 1880 Milliohm meter

Operating temperature rang: -40°C to +125°C

Storage temperature rang: -40°C to +125°C

Note: All specifications subject to change without notice.

# ISOLATION TRANSFORMERS FOR NARROWBAND PLC SYSTEMS

## T5032 Series

### FEATURES:

- Excellent transmission characteristics
- High mains current capability, low THD
- Matching with all leading IC (modulation methods FSK, DCSK and OFDM)
- Compliant with all PLC standards (HomePlug, CENELEC ...)
- Compact designs in THT and SMT housings
- Insulation according to IEC 60950, UL 1950 and IEC 61558

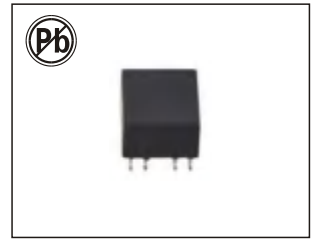

### DESCRIPTION:

For narrowband PLC systems where the operating frequency may be up to 500 kHz isolation transformers based on amorphous or nanocrystalline offer excellent transmission characteristics, high robustness against EMC interferences and safe galvanic insulation.

### STANDARD SPECIFICATION:

Part Number	Turns ratio	Sec. current (mA)Max	Sec. Inductance (mH)Min	Sec. Leakage inductance (Short Pri.) (uH)	Capacitance Pri to Sec (pF)Typ.	Sec. DCR (Ω)Typ.	Insulation voltage Pri. to Sec. (V)	Hi-Pot (kV)
T5032-104	1:1	90	0.5	6.6	15	0.09	100	1.0
T5032-111	2:1	130	0.3	5.8	7	0.17	300	3.0
T5032-102	1:1:2	100	0.7	1	30	0.23	450	5.1
T5032-114	1:1.15:1.62	120	0.54	1	30	0.22	450	5.1

### PHYSICAL CHARACTERISTICS

### TECHNICAL INFORMATION:

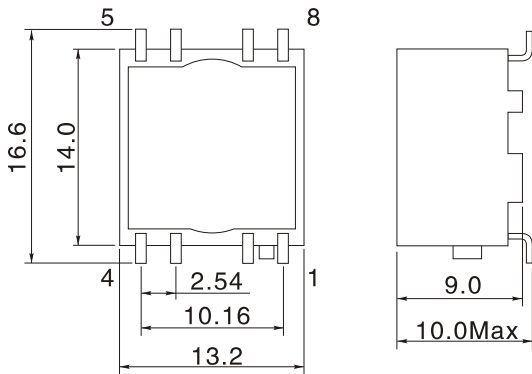

Winding 1

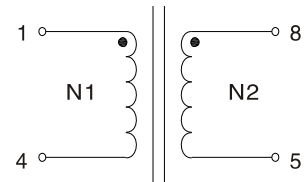

Winding 2

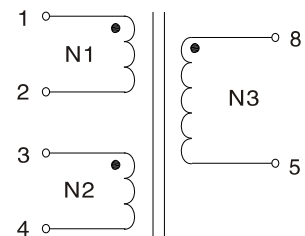

**Notes:**

- Electrical specification at 25°C
- Testing: LCR Bridge measured @ 1KHz 0.1V HP 4284A (Equivalent acceptable)
- RDC: QuadTech 1880 Milliohm meter
- Operating temperature rang: -40°C to +125°C
- Storage temperature rang: -40°C to +125°C

Note: All specifications subject to change without notice.